

- Works are gripped firmly by the formed jaws. ensuring high precision. (Deviation: within 0.03mm)* Use forming rings (jaw locks) to form the soft-jaws.
- Large workpieces can be held tight with the low profile vise body.
- Able to grip square works by using this chuck as a two-way jaw unit * The fixed jaw(optional)is necessary. Longitudinal works can also be gripped by using the bore of this chuck.
- A dust cover is provided and this keeps the shavings from entering the machine.
- The handle is set on the face and does not interfere with the table. A number of chucks can be used together.

SPECIFICATIONS

Unit:mm

ORDER NO.	A	B	C	D	E	G	H	I	J	K	L	M	N	MAX. GRIPPING DIAMETER		Gripping Force (kgf)	WEIGHT (kgs)	CODE NO.
														CLAMPING DIA	PROPING DIA			
VMJ-6	165	215	144	18	25	26	130	40	18	57	96	39	4-M10	Ø4-Ø128	Ø55-Ø128	900	13.5	5002-240
VMJ-8	200	250	174	18	25	28	160	55	20	65	108	43	4-M12	Ø5-Ø162	Ø62-Ø162	1620	21.5	5002-241
VMJ-10	250	310	218	18	30	32	200	70	22	72	122	50	4-M14	Ø6-Ø200	Ø72-Ø200	1800	36.1	5002-242
VMJ-12	310	380	274	22	35	40	260	100	25	85	141	56	4-M16	Ø10-Ø265	Ø90-Ø265	2250	62.8	5002-243

Super Thin Chucks

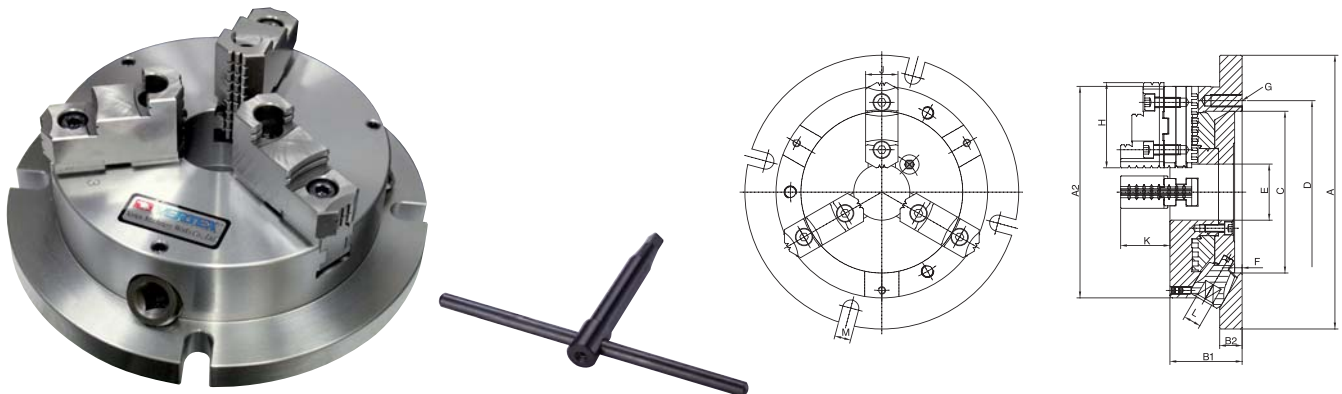

- The angle between "HANDLE" AND "BASE OF CHUCK" is 30° degree, There Fore, it is much more convenient for "HANDLE" rotation.
- This "POWER SUPER THIN" design of chuck may increase the "allowable length" of machining operation.
- The flanged type design make it easily for loading and unloading operation. Four locate position 90°.
- "POWERFUL TYPE" design.

SPECIFICATIONS

Unit:mm

ORDER NO.	Dim														Gripping Force (kgf)	Weight (kgs)	Gripping Range		CODE NO.
	A1	A2	B1	B2	C	D	E	F	G	H	J	K	L	M			O.D. Range	I.D. Range	
	VNBK-6	220	170	58	18	130	147	45	6	3-M10	68	26	40	10			13	1800	
VNBK-8	270	210	65	20	155	172	60	6	3-M10	82	28	43	11	13	2250	20.2	Ø11-200	Ø62-190	5002-071
VNBK-10	315	255	73	20	190	210	80	6	3-M12	93	32	52	12	16	3150	30.5	Ø12-250	Ø72-240	5002-072
VNBK-12	370	305	80	22	250	285	105	5	3-M12	118	40	59	14	18	3670	46.8	Ø15-300	Ø86-290	5002-073