



# Precision Finish Boring Head Sets



Boring diameter Ø 6-150 mm

**NEW**

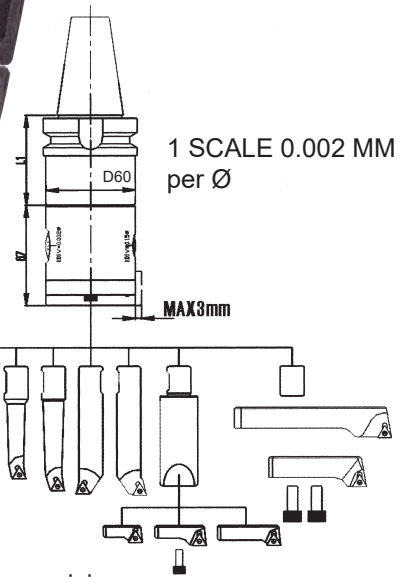

- Processing range Ød 6-150 mm.
- This slim set allows customer to process boring work in the narrow space with high precision.
- Please keep boring head clean and lubricate constantly.
- Precisely ground and hardened shank integrating with boring head for routing and smooth operation.



BORING HEAD SETS

## SET TYPE

ORDER NO.	Boring Range Ø	Shank	L1	Head Dia. ØD	PCS/SET	CODE NO.
VBHE-BT-40	6-150	BT40-VCK5-60	60	60	15 PCS/SET	3320-460
VBHE-BT-50		BT50-VCK5-75	75			3320-461
VBHE-SK-40		SK40-VCK5-65	65			3320-462
VBHE-SK-50		SK50-VCK5-75	75			3320-463
VBHE-NT-40		NT40-40-VCK5-60	60			3320-464
VBHE-NT-50		NT50-50-VCK5-75	75			3320-465
VBHE-HSK63A		HSK63A-VCK5-75	75			3320-466
VBHE-HSK100A		HSK100A-VCK5-75	75			3320-467

## VBHE SHANK

ORDER NO.	L	WEIGHT	CODE NO.
BT40-VCK5-60	60		3320-460S
BT50-VCK5-75	75		3320-461S
SK40-VCK5-65	95		3320-462S
SK50-VCK5-75	75		3320-463S
NT40-40-VCK5-60	60		3320-464S
NT50-50-VCK5-75	75		3320-465S
HSK63A-VCK5-75	75		3320-466S
HSK100A-VCK5-75	75		3320-467S

## ACCESSORIES: BORING BAR SIZE FOR SET TYPE

Boring Bar	Range d	Depth m	Insert	Screw	Wrench	Feed mm/REV.
BR-1606-20	6-9	20	WBGT060102L	TS2	T6	0.05-0.1
BR-1608-28	8-11	28	TBGT060102L			0.05-0.1
BR-1610-36	10-13	36	TBGT060104L			0.07-0.15
BR-1612-42	12-15	42	TPGT090202L	TS25	T8	0.05-0.1
BR-1614-50	14-17	50				
BR-1616-60	16-20	60				
BR-1620-63	20-24	63	TPGT090204L			0.07-0.15
BR-1624-64	24-28	64				
BM5		60+SRTP2838/SRTP3652/SRTP4470		M5 X15 CAP	4	0.05-0.1
SRTP2838	28-38	+10	TPGT090202L	TS25	T8	
SRTP3652	36-52	+12				
SRTP4470	44-70	+12				
BM8				M8 X 15 CAP	6	0.05-0.1
SRTP70110	70-110	+20	TPGT090202L	TS25	T8	
SRTP110150	110-150	+20	TPGT090204L			