



# Precision Finish Boring Head Sets



Boring diameter Ø 6-90 mm

**NEW**

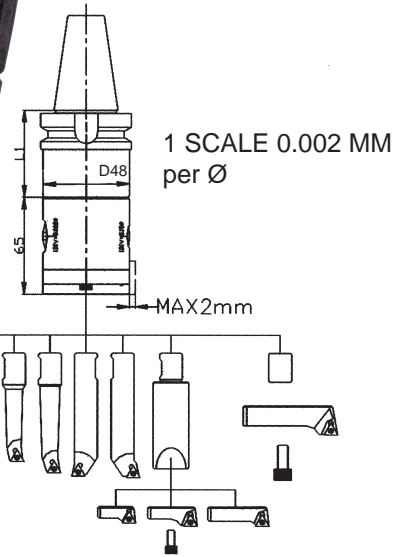

- Processing range Ød 6-90 mm.
- This slim set allows customer to process boring work in the narrow space with high precision.
- Precisely ground and hardened shank integrating with boring head for routing and smooth operation.
- Please keep boring head clean and lubricate constantly.



## SET TYPE

## VBHD SHANK

ORDER NO.	Boring Range Ø	Shank	L1	Head Dia. ØD	PCS/SET	CODE NO.	ORDER NO.	L	WEIGHT	CODE NO.
VBHD-BT-30	6-90	BT30-VCK4-45	45	48	14 PCS/SET	3320-450	BT30-VCK4-45	45		3320-450S
VBHD-BT-40		BT40-VCK4-60	60			3320-451	BT40-VCK4-60	60		3320-451S
VBHD-BT-50		BT50-VCK4-75	75			3320-452	BT50-VCK4-75	75		3320-452S
VBHD-SK-40		SK40-VCK4-65	65			3320-453	SK40-VCK4-65	65		3320-453S
VBHD-SK-50		SK50-VCK4-75	75			3320-454	SK50-VCK4-75	75		3320-454S
VBHD-NT-40		NT40-40-VCK4-60	60			3320-455	NT40-40-VCK4-60	60		3320-455S
VBHD-NT-50		NT50-50-VCK4-60	60			3320-456	NT50-50-VCK4-60	60		3320-456S
VBHD-HSK63A		HSK63A-VCK4-75	75			3320-457	HSK63A-VCK4-75	75		3320-457S
VBHD-HSK100A		HSK100A-VCK4-75	75			3320-458	HSK100A-VCK4-75	75		3320-458S

## ACCESSORIES: BORING BAR SIZE FOR SET TYPE

Boring Bar	Range d	Depth m	Insert	Screw	Wrench	Feed mm/REV.
BR-1606-20	6-9	20	WBGT060102L	TS2	T6	0.05-0.1
BR-1608-28	8-11	28	TBGT060102L			0.05-0.1
BR-1610-36	10-13	36	TBGT060104L			0.07-0.15
BR-1612-42	12-15	42	TPGT090202L	TS25	T8	0.05-0.1
BR-1614-50	14-17	50				
BR-1616-60	16-20	60	TPGT090204L			0.07-0.15
BR-1620-63	20-24	63				
BR-1624-64	24-28	64				
BM5		60+SRTP2838/SRTP3652/SRTP4470		M5 X15 CAP	4	0.05-0.1
SRTP2838	28-38	+10	TPGT090202L	TS25	T8	
SRTP3652	36-52	+12				
SRTP4470	44-70	+12	TPGT090204L			
BM8				M8 X 15 CAP	6	0.07-0.15
SRTP58-90	58-90	+20	TPGT090204L	TS25	T8	