

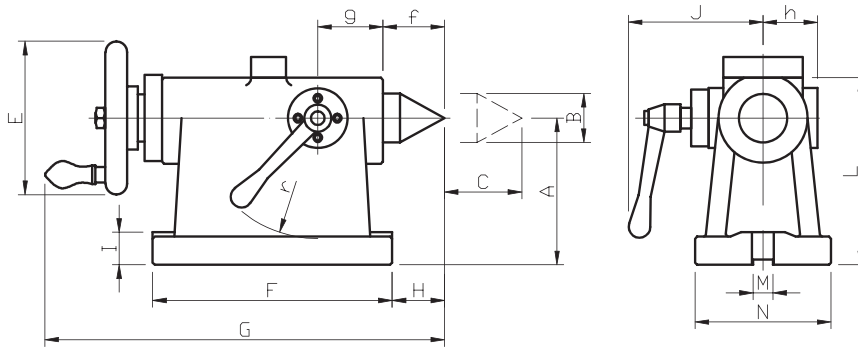

Tailstock For NC Rotary Table



Unit:mm

Main dimension		Center height A	Center diameter B	Storke C	pointed end diameter D	Handle diameter E	Base dimensions FXM	G	H	I	J	K	L
ORDER NO.	For												
TS-135	VNCM-150	135	ø45 MT#3	55	ø14	125	215x120	332	25	25	109	-	164
TS-135-MT3													
TS-160	VNCM-220 VNCX-10 VNCM-250	160	ø45 MT#3		ø18	140	230x130	356	30	30	129	53	193
TS-160-MT3													
TS-210	VNCM-320	210					230x146						243
TS-210-MT3													

Unit:mm

Main dimension		Guide-block size M	c	u	f	g	h	j	r	Net weight (kgs)	CODE NO.
ORDER NO.	For										
TS-135	VNCM-150	18	42	19	40	69	44	70	80	20.6	4002-001
TS-135-MT3			46								4002-001A
TS-160	VNCM-220 VNCX-10 VNCM-250		49	19	45	70	52	80	95	23.1	4002-002
TS-160-MT3			51								4002-002A
TS-210	VNCM-320		51	23						29.4	4002-003
TS-210-MT3			57								4002-003A

Listed in the above table are examples of applicable models. Those not listed above should be selected so that the center height of the rotary table and dividing heads is the same as that of the tailstock.