



Quick Change Tapping Chuck



European Type

SPECIAL!

**SAFETY!
QUICK!**



TAPPING CHUCKS

QUICK CHANGE TAPPING CHUCKS (with length compensation)

MAS-BT-30, 40, 50 Shank / DIN69871A SK-40, 50 / ST-20, 32 / MT-2, 3, 4

- Tension and compression feature allows taps to follow their own thread lead.
- With extreme light compression compression and tension operated by ball cage.



Quick Change Tapping Chucks

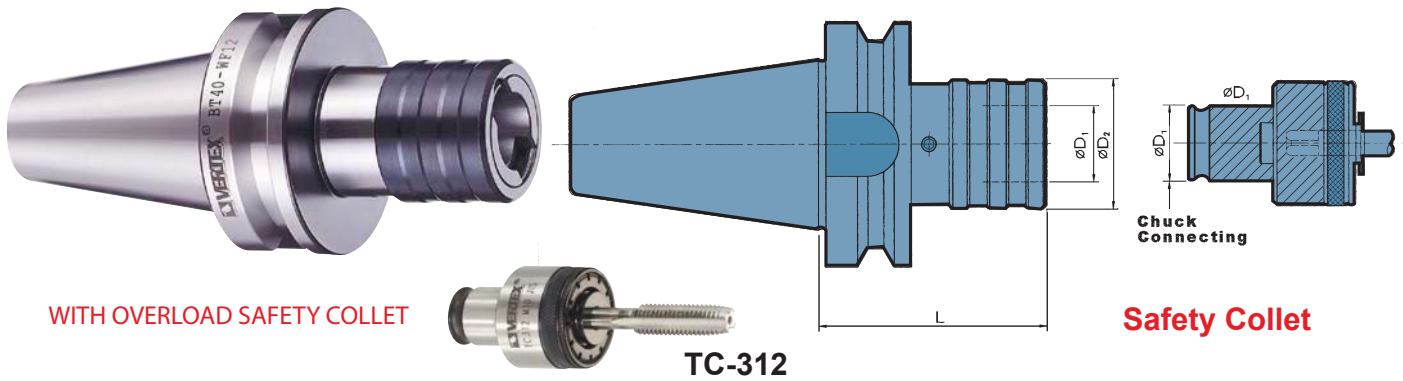

- Tension and compression feature allows taps to follow their own thread lead.
- With extreme light compensation compression and tension operated by ball cage.

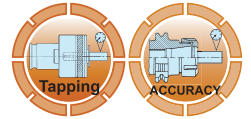

WF-BT30/BT40/SK30/SK40 LENGTH COMPENSATION TYPE

ORDER NO.	Thread Size	L	ØD ₁ Chuck Connecting DIA.	ØD ₂	Length Compensation		Tapping Collets	WEIGHT (kg)	CODE NO.
					Compression	Tension			
BT30-WF12	M2-M14	70	Ø19	36	7.5	7.5	TC-312	0.8	3404-050A
BT40-WF12	M2-M14	75	Ø19	36	7.5	7.5	TC-312	1.3	3404-050
SK40-WF12								1.3	3404-051
BT30-WF20	M5-M24	94	Ø31	53	12.5	12.5	TC-820	1.3	3404-052A
BT40-WF20	M5-M24	95	Ø31	53	12.5	12.5	TC-820	1.8	3404-052
SK40-WF20	M5-M24	95	Ø32	53	12.5	12.5	TC-820	1.8	3404-053

※Tapping Collet Reducer Adapter : TC820 / TC312-AD



Quick Change Tapping Chucks

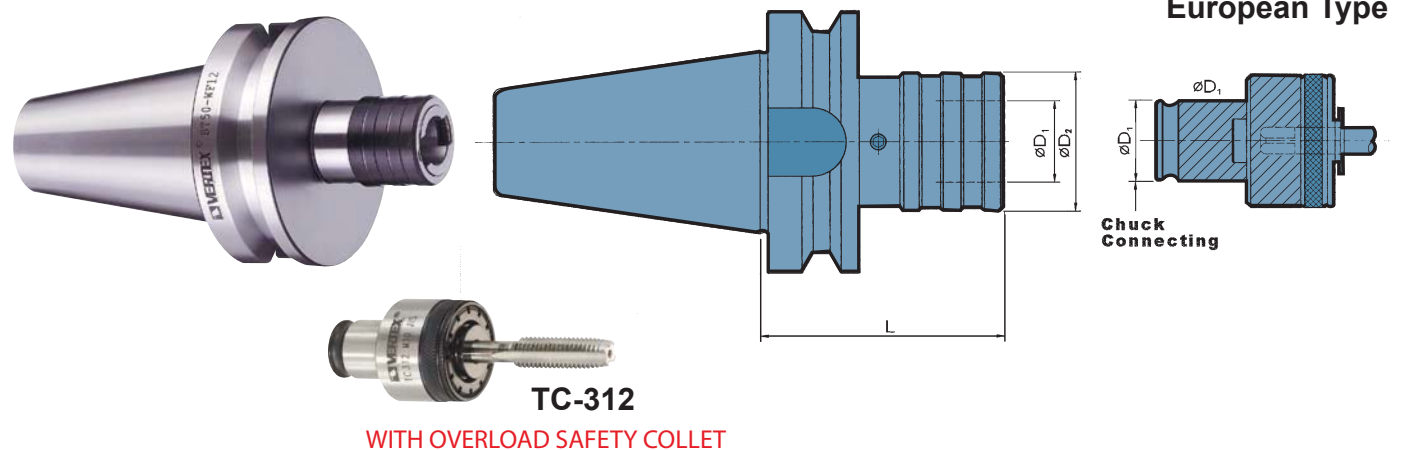

- Tension and compression feature allows taps to follow their own thread lead.
- With extreme light compensation compression and tension operated by ball cage.

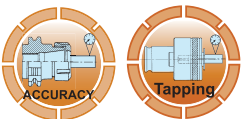

WF-BT50/SK50 LENGTH COMPENSATION TYPE

ORDER NO.	Thread Size	L	ØD ₁ Chuck Connecting DIA.	ØD ₂	Length Compensation		Collets	WEIGHT (kg)	CODE NO.
					Compression	Tension			
BT50-WF12	M2-M14	85	Ø19	36	7.5	7.5	TC-312	4	3404-060
SK50-WF12								4	3404-061
BT50-WF20	M5-M24	105	Ø31	53	12.5	12.5	TC-820	4.1	3404-062
SK50-WF20								4.1	3404-063
BT50-WF33	M14-M36	142	Ø48	78	20	20	TC-1433	5.8	3404-064

※Tapping Collet Reducer Adapter : TC820 / TC312-AD TC1433 / TC820-AD



Quick Change Tapping Chucks



**QUICK CHANGE TAPPING CHUCKS (with length compensation)
STRAIGHT SHANK**

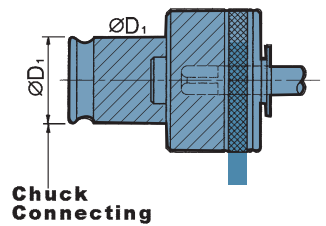
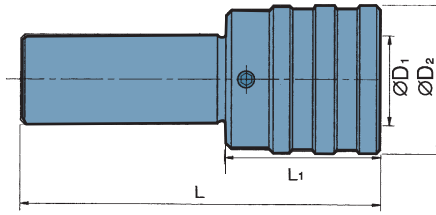

Chuck Connecting

WITH OVERLOAD SAFETY COLLET



TC-312

- Tension and compression feature allows taps to follow their own thread lead.
- With extreme light compensation compression and tension operated by ball cage.

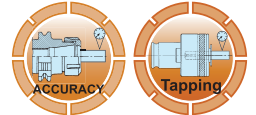

WF-ST LENGTH COMPENSATION TYPE

ORDER NO.	Thread Size	L	L1	ØD1 Chuck Connecting DIA.	ØD2	Length Compensation		Collets	WEIGHT (kg)	CODE NO.
						Compression	Tension			
ST20-WF12	M2-M14	105	40	Ø19	36	7.5	7.5	TC-312	0.4	3404-087
ST32-WF12				Ø31						
ST20-WF20	M5-M24	120	65	Ø31	53	12.5	12.5	TC-820	1	3404-089
ST32-WF33	M14-M36	183	80	Ø48	78	20	15	TC-1433	2.7	3404-092

※Tapping Collet Reducer Adapter : TC820 / TC312-AD TC1433 / TC820-AD



Quick Change Tapping Chucks

Solid Type

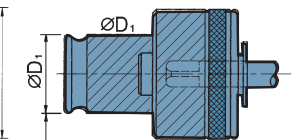
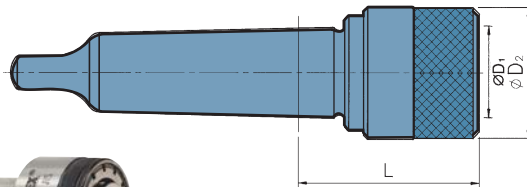

Chuck Connecting

WITH OVERLOAD SAFETY COLLET



TC-312

- Tension and compression feature allows taps to follow their own thread lead.
- With extreme light compensation compression and tension operated by ball cage.

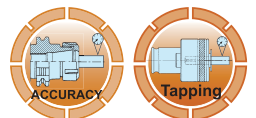

WF-MT LENGTH COMPENSATION TYPE

ORDER NO.	Thread Size	Morse.Taper MT	L	ØD1 Chuck Connecting DIA.	ØD2	Lenght Compensation		Collets	WEIGHT (kg)	CODE NO.
						Compression	Tension			
MT2-WF12	M2-M14	MT2	47.5	Ø19	36	7.5	7.5	TC-312	0.4	3404-123
MT3-WF12		MT3								
MT4-WF12		MT4	49							
MT2-WF20	M5-M24	MT2	70	Ø31	53	12.5	12.5	TC-820	0.8	3404-124
MT3-WF20		MT3								
MT4-WF20		MT4	1.5							
MT3-WF33	M14-M36	MT3	103	Ø48	78	20	15	TC-1433	2.2	3404-125
MT4-WF33		MT4								

※Tapping Collet Reducer Adapter : TC820 / TC312-AD TC1433 / TC820-AD



Quick Change Tapping Chucks



QUICK CHANGE TAPPING CHUCKS (with length compensation)

MAS-BT SHANK / DIN69871A SHANK

- Tension and compression feature allows taps to follow their own thread lead.

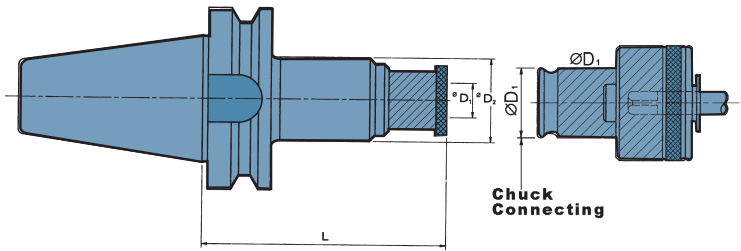

WITH OVERLOAD SAFETY COLLET



TC-312

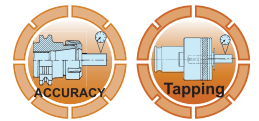

WFE-BT40 LENGTH COMPENSATION TYPE

ORDER NO.	Thread Size	L	$\varnothing D_1$ Chuck Connecting DIA.	$\varnothing D_2$	Length Compensation		Collets	WEIGHT (kg)	CODE NO.
					Compression	Tension			
BT40-WFE12-135	M2-M14	135	$\varnothing 19$	46	15	20	TC-312	1.5	3404-070
BT40-WFE12-165		165						2.4	3404-072

※Tapping Collet Reducer Adapter : TC820 / TC312-AD TC1433 / TC820-AD



Quick Change Tapping Chucks

QUICK CHANGE TAPPING CHUCKS (with length compensation)

MAS-BT SHANK / DIN69871A SHANK

- Tension and compression feature allows taps to follow their own thread lead.

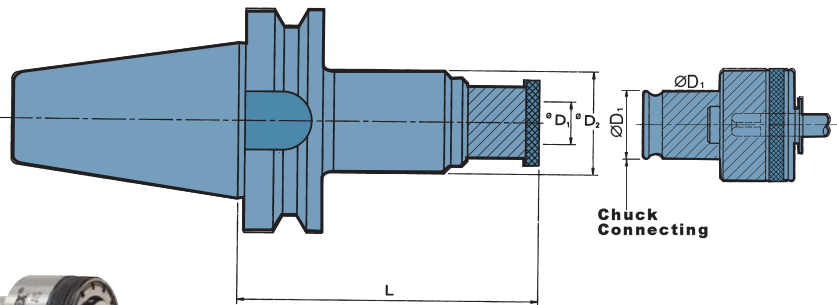

WITH OVERLOAD SAFETY COLLET



TC-312

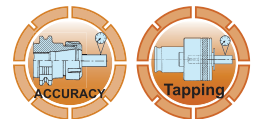

WFE-BT50 LENGTH COMPENSATION TYPE

ORDER NO.	Thread Size	L	$\varnothing D_1$ Chuck Connecting DIA.	$\varnothing D_2$	Length Compensation		Collets	WEIGHT (kg)	CODE NO.
					DIA.	Tension			
BT50-WFE12-135	M2-M14	135	$\varnothing 19$	46	15	20	TC-312	4.54	3404-080
BT50-WFE12-165		165						4.94	3404-082
BT50-WFE20-165	M5-M24	165	$\varnothing 31$	58	15	15	TC-820	7	3404-084

※Tapping Collet Reducer Adapter : TC820 / TC312-AD TC1433 / TC820-AD



Quick Change Tapping Chucks



MSA-BT SHANK & DIN 69871A SHANK

Solid Type

- No tension or compensation stroke for use in synchronous tapping(rigid tapping) cycle.

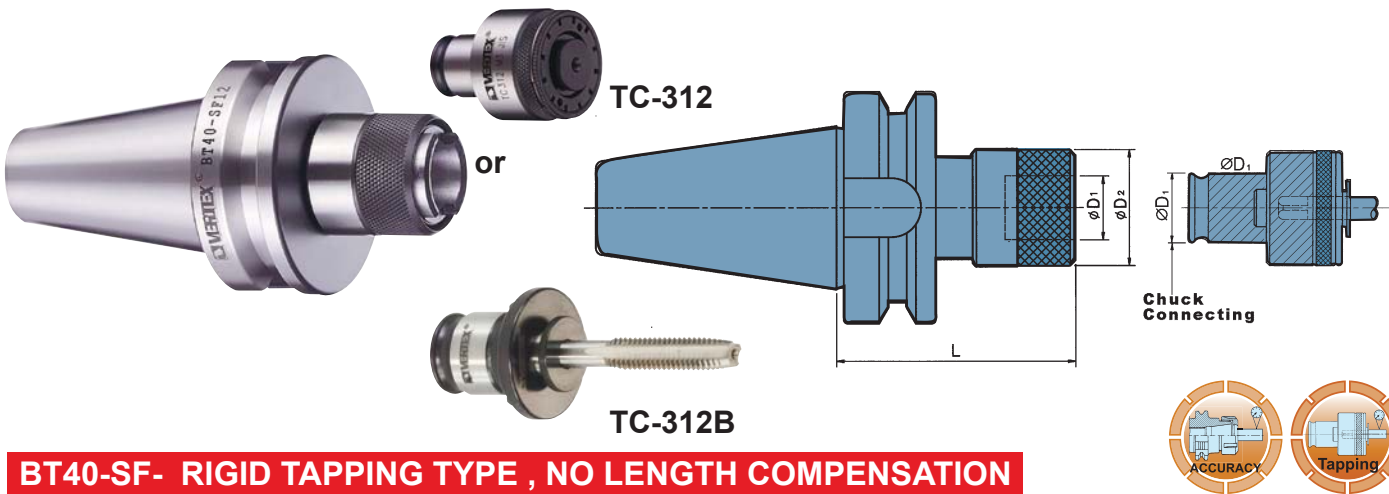

BT40-SF- RIGID TAPPING TYPE , NO LENGTH COMPENSATION

ORDER NO.	Thread Size	L	ØD1 Chuck Connecting DIA.	ØD2	Collets	WEIGHT (kg)	CODE NO.
BT40-SF12	M2-M14	72	Ø19	34	TC-312 TC-312B	1	3404-100
BT40-SF20	M5-M24	91	Ø31	50	TC-820 TC-820B	1.4	3404-102
BT40-SF33	M14-M36	130	Ø48	74	TC-1433 TC-1433B	3.5	3404-104

※Tapping Collet Reducer Adapter : TC820 / TC312-AD TC1433 / TC820-AD



Quick Change Tapping Chucks

MSA-BT SHANK & DIN 69871A SHANK

Solid Type

- No tension or compensation stroke for use in synchronous tapping(rigid tapping) cycle.

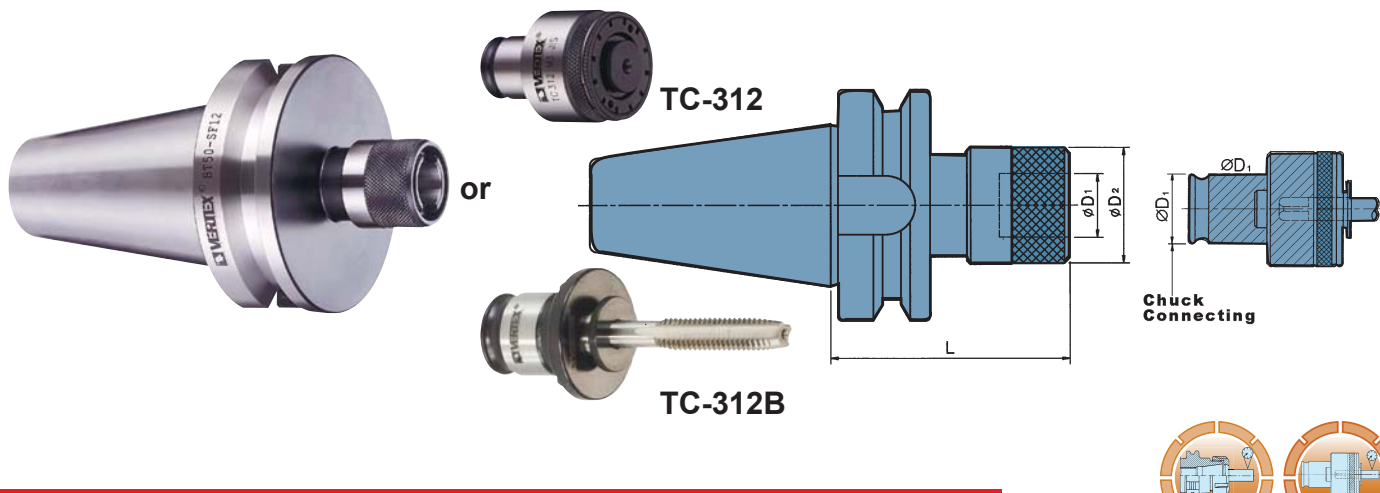

BT50-SF- RIGID TAPPING TYPE, NO LENGTH COMPENSATION

ORDER NO.	Thread Size	L	ØD1 Chuck Connecting DIA.	ØD2	Collets	WEIGHT (kg)	CODE NO.
BT50-SF12	M2-M14	78	Ø19	34	TC-312 TC-312B	3.6	3404-110
BT50-SF20	M5-M24	95	Ø31	50	TC-820 TC-820B	4	3404-112
BT50-SF33	M14-M36	142	Ø48	74	TC-1433 TC-1433B	5.6	3404-116

※Tapping Collet Reducer Adapter : TC820 / TC312-AD TC1433 / TC820-AD



Quick Change Tapping Chucks



QUICK CHANGE TAPPING CHUCKS

Solid Type

MORSE TAPER SHANK

- Tension and compression feature allows taps to follow their own thread lead.
- With extreme light compensation compression and tension operated by ball cage.

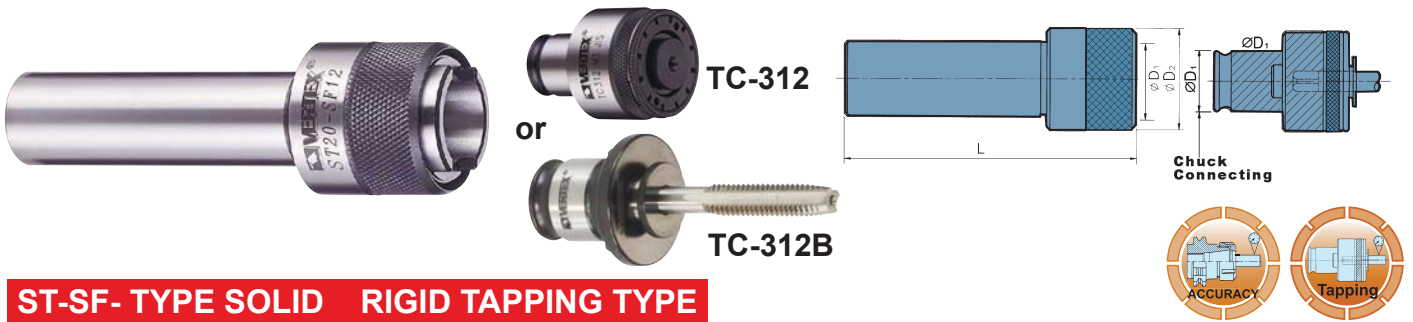

ST-SF- TYPE SOLID RIGID TAPPING TYPE

ORDER NO.	Thread Size	L	L1	ØD1 Chuck Connecting DIA.	ØD2	Collets	WEIGHT (kg)	CODE NO.
ST20-SF12	M2-M14	104	70	Ø19	34	TC-312	0.3	3404-140
ST32-SF12		106		Ø19		TC-312B	0.66	3404-140A
ST20-SF20	M5-M24	105		Ø31	50	TC-820	0.74	3404-141
ST32-SF20				Ø31		TC-820B	1.02	3404-141A
ST32-SF33	M14-M36	169		Ø48	76	TC-1433 TC-1433B	2.86	3404-142A

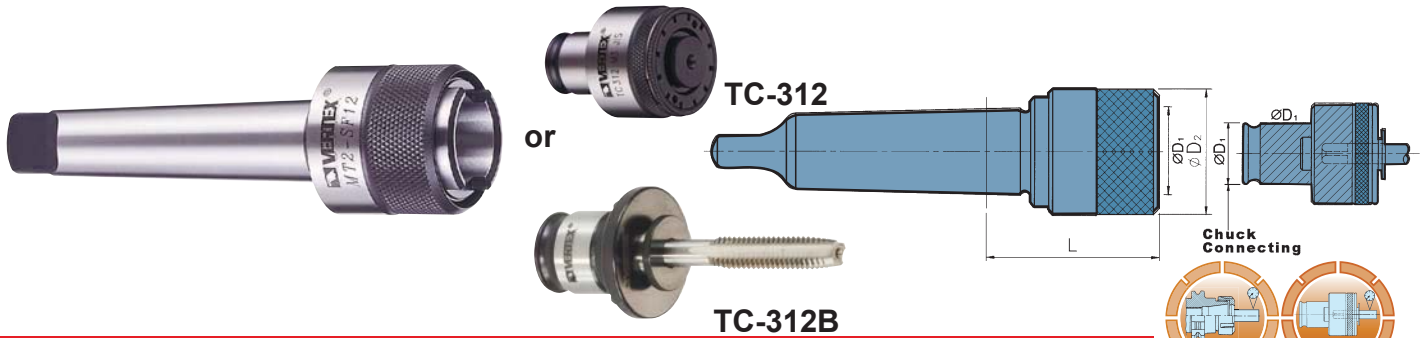

MT-SF- TYPE SOLID RIGID TAPPING TYPE, NO LENGTH COMPENSATION

ORDER NO.	Thread Size	Morse Taper MT	L	ØD1 Chuck Connecting DIA.	ØD2	Collets	WEIGHT (kg)	CODE NO.
MT2-SF12	M2-M14	MT2	45	Ø19	34	TC-312 TC-312B	0.3	3404-120
MT3-SF12		MT3					0.8	3404-120A
MT4-SF12		MT4					0.8	3404-120B
MT2-SF20	M5-M24	MT2	70	Ø31	50	TC-820 TC-820B	0.6	3404-121A
MT3-SF20		MT3					0.8	3404-121
MT4-SF20		MT4					1.18	3404-121B
MT3-SF33	M14-M36	MT3	99	Ø48	74	TC-1433 TC-1433B	0.84	3404-122A
MT4-SF33		MT4	99				2.2	3404-122

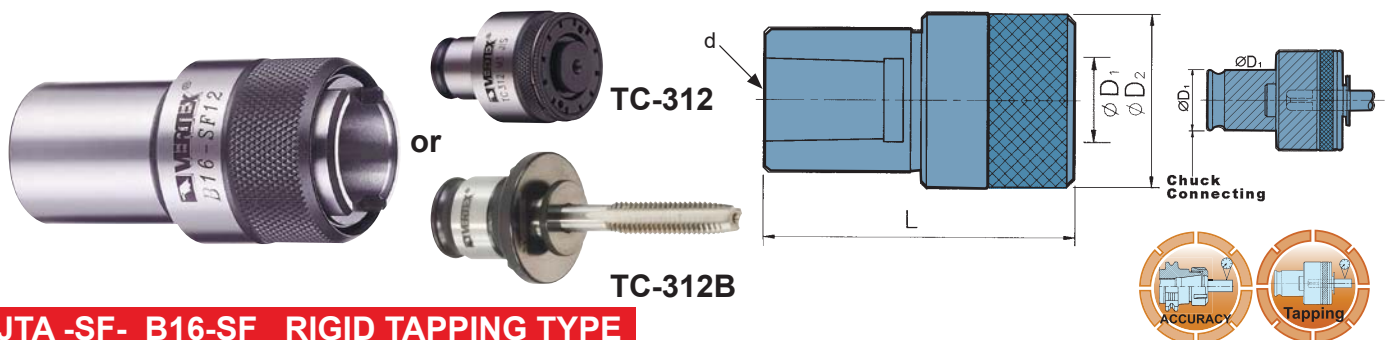

JTA -SF- B16-SF RIGID TAPPING TYPE

ORDER NO.	Thread Size	L	ØD1 Chuck Connecting DIA.	ØD2	d	Collets	WEIGHT (kg)	CODE NO.
JTA6-SF12	M2-M14	66	Ø19	32	JT6	TC-312 TC-312B	0.3	3404-130
B16-SF12					B16		0.22	3404-130A
B12-SF12					B12		0.2	3404-130B

※ Tapping Collet Reducer Adapter : TC820 / TC312-AD TC1433 / TC820-AD



Quick Change Tapping Chucks Set



Shank with length compensation

European Type

NEW



- Tension and compression feature allows taps to follow their own thread lead.
- With extreme light compensation compression and tension operated by ball cage.



Collets Size	
TC-312	M3, M4, M5, M6, M8, M10, M12
TC-820	M8, M10, M12, M14, M16, M18, M20

SET TYPE BT-WF
SHANK WITH 7 PCS/SET OVERLOAD CLUTCH
TAPPING COLLET DIN, ISO & JIS SYSTEMS:
PLEASE SEE PAGE 119.

Please inform the collet size when ordering.
Please use following page as reference for collet size.

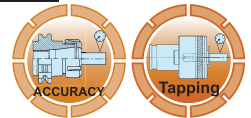

TAPPING CHUCKS

SETS

ORDER NO.	Shank Size	Thread Size	L	ØD1	ØD2	Length Compensation		Collets	PCS/SET	CODE NO.
						Compression	Tension			
VQT-312	BT-30-WF12	M3-M12	70	19	36	7.5	7.5	TC-312	7PCS	3404-190
VQT-320	BT-30-WF20	M8-M20	105	31	53	12.5	12.5	TC-820	7PCS	3404-191
VQT-412	BT-40-WF12	M3-M12	75	19	36	7.5	7.5	TC-312	7PCS	3404-192
VQT-420	BT-40-WF20	M8-M20	95	31	53	12.5	12.5	TC-820	7PCS	3404-193
VQT-512	BT-50-WF12	M3-M12	85	19	36	7.5	7.5	TC-312	7PCS	3404-194
VQT-520	BT-50-WF20	M8-M20	105	31	53	12.5	12.5	TC-820	7PCS	3404-195



Quick Change MT Tapping Chuck Set

With Overload Clutch

NEW



- Tension and compression feature allows taps to follow their own thread lead.
- With extreme light compensation compression and tension operated by ball cage.

SET TYPE MT-SF
SHANK WITH 7 PCS/SET OVERLOAD CLUTCH
TAPPING COLLET DIN, ISO & JIS SYSTEMS:
PLEASE SEE PAGE 119.

Collets Size	
TC-312	M3, M4, M5, M6, M8, M10, M12
TC-820	M8, M10, M12, M14, M16, M18, M20

Please inform the collet size when ordering.
Please use following page as reference for collet size.

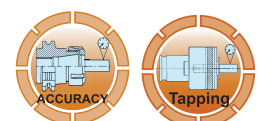

SETS

ORDER NO.	Shank Size	Thread Size	L	ØD2	Collets	PCS/SET	CODE NO.
VQT-712	MT3-SF12	M3-M12	39	32	TC-312	7PCS	3404-196
VQT-812	MT4-SF12	M3-M12	34	32	TC-312	7PCS	3404-197
VQT-720	MT3-SF20	M8-M20	59	50	TC-820	7PCS	3404-198
VQT-820	MT4-SF20	M8-M20	55	50	TC-820	7PCS	3404-199

Tapping Collet Reducer Adapter

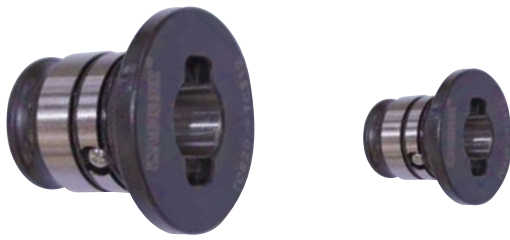

This adapter is for transforming
This adapter allows the tapping chuck to use smaller size.
Transforming the big tapping size to smaller one.
large range type for tap M3~M24, TC312, TC820, TC1433
COST SAVING!

SIZE CONVERTER

ORDER NO.	TRANSFORMING SIZE	WIGHT	CODE NO.
TC820/TC312-AD	TC820 TO TC312	0.2	3404-461
TC1433/TC820-AD	TC1433 TO TC820	0.6	3404-462

※ Every tap needs a match size tapping collet.

Adjustable Wrenches

For Tapping Collet's Torque Force Adjustment



NEW

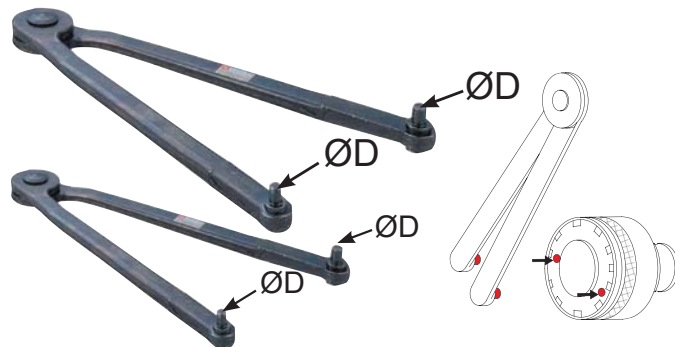

- Tool for Setting
- Time Saving

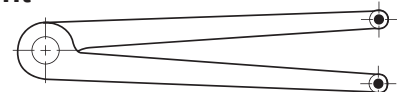

EXAMPLE



ORDER NO.	SIZE	ØD	COLLETS	WEIGHT	CODE NO.
VWR-40	7-40	2.5	TC-312 / TC-820	0.15 kgs	3404-150
VWR-60	11-60	4	TC1433	0.15 kgs	3404-151

Quick Change Tapping Collet TC312 8PCS/SET

ORDER NO. TC-312-DIN371-A

CODE NO. 3404-175

NEW



**QUICK CHANGE TAP COLLETS
(with overload safety collet)**

TC-312 DIN371 8PCS/SET
(M1, M2, M3, M3.5, M4, M4.5, M8, M10)

NO.	ØD X □ SIZE SAME AS DIN371 TC312
1	M1, M1.1~M1.8
2	M2, M2.5, M2~M2.5
3	M3
4	M3.5
5	M4
6	M4.5, M5, M6
7	M8
8	M10

Quick Change Tapping Collet TC312 8PCS/SET

ORDER NO. TC-312-DIN376-B

CODE NO. 3404-176

NEW



**QUICK CHANGE TAP COLLETS
(with overload safety collet)**

TC-312 DIN376 8PCS/SET
(M4, M5, M6, M7, M8, M10, M12, M14)

NO.	ØD X □ SIZE SAME AS DIN376 TC312
1	M4
2	M5, M4.5
3	M6
4	M7
5	M8
6	M10
7	M12
8	M14



Quick Change Tapping Collet TC820 8PCS/SET



ORDER NO. TC820-DIN 376-C

CODE NO. 3404-177

NEW

QUICK CHANGE TAP COLLETS
(with overload safety collet)

TC-820 DIN376 8PCS/SET
(M8, M10, M12, M14, M16, M18, M20, M22)



NO.	ØD X □ SIZE SAME AS DIN376 TC820
1	M8
2	M10
3	M12
4	M14
5	M16
6	M18
7	M20
8	M22, M24



Quick Change Tapping Collet TC820 4PCS/SET

ORDER NO. TC820-DIN 371-D

CODE NO. 3404-178

NEW

QUICK CHANGE TAP COLLETS
(with overload safety collet)

TC-820 DIN371 4PCS/SET
(M5, M6, M8, M10)



NO.	ØD X □ SIZE SAME AS DIN371 TC820
1	M5, M6
2	M6, M5
3	M8
4	M10



Quick Change Tapping Collet TC820 8PCS/SET

ORDER NO. TC820-ISO2283-E

CODE NO. 3404-179

NEW

QUICK CHANGE TAP COLLETS
(with overload safety collet)

TC-820 ISO2283 8PCS/SET
(M8, M10, M12, M14, M16, M18, M22, M24)



NO.	ØD X □ SIZE SAME AS ISO2283 TC820
1	M8
2	M10
3	M12
4	M14
5	M16
6	M18, M20
7	M22
8	M24

TAPPING CHUCKS



Quick Change Tapping Collet



QUICK CHANGE TAP COLLETS
(with overload safety collet)

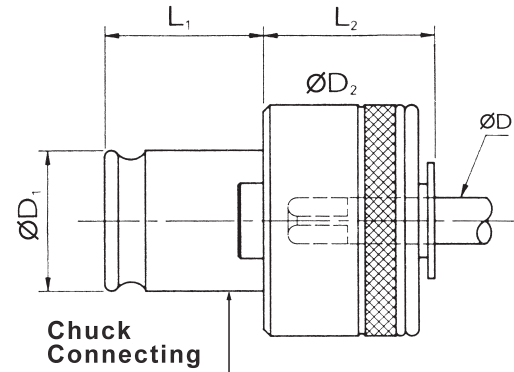

CHUCK SUIT FOR DIA. ØD1
 TC-312,312B IS Ø19 MM
 TC-820,820B IS Ø31 MM
 TC-1433,1433B IS Ø48 MM

- Torque is factory-set to protect the tap. Small adjustments can be made by a trained user to accommodate tap strength and material variations.
- Collet stops driving when set torque is exceeded.
- Every tap needs a match size tapping collet.
- ØD1 is chuck suit for dia.

Tapping Collet Reducer / Adapter

This adapter is for transforming
 This adapter allows the VAT-tapping spindle to use smaller size.
 Transforming the big tapping size to smaller one.

Large range type for tap M3~M24,
 TC312, TC820, TC1433
 COST SAVING!
 Please see the page C118



Connecting Size List

QUICK CHANGE TAP COLLETS
(with overload safety collet)



1PC ≒ 0.18kg

JIS SYSTEM SIZE ※ORDER NO. SAME COLOR ARE INTER-CHANGEABLE

Size	Thread	Tap Shank		Ø D1	L1	L2	ORDER NO.	CODE NO.	ØD x □ Size same as JIS inch or mm
		ØD	□						
TC 312 (#1)	M2	3	2.5	Suit for DIA. 19	22	25	312-00	3404-200A	
	M3	4	3.2				312-01	3404-200	W1/8"
	M4	5	4				312-02	3404-201	M4.5
	M5	5.5	4.5				312-03	3404-202	M5.5, W3/16"
	M6	6	4.5				312-04	3404-203	W1/4", UNC1/4"
	M7	6.2	5				312-05	3404-204	M8
	M8	6.2	5				312-06	3404-205	M7
	M9	7	5.5				312-07	3404-206	M10, W3/8", UNC3/8"
	M10	7	5.5				312-08	3404-207	M9, W3/8", UNC3/8"
	M11	8	6				312-09	3404-208	W7/16", PT1/8", PS1/8", PF1/8", UNC7/16"
	M12	8.5	6.5				312-10	3404-209	
	•M14	10.5	8				•312-11	3404-210	M15, W9/16", UNC9/16"
	•M15	10.5	8				•312-12	3404-211	M14, W9/16", UNC9/16"
	UNC 1/4	6	4.5				312-13	3404-212	M6, W1/4"
	UNC 5/16	6.1	5				312-14	3404-213	
	UNC 3/8	7	5.5				312-15	3404-214	M9, M10, W3/8"
	UNC 7/16	8	6				312-16	3404-215	M11, W7/16", PT1/8", PS1/8", PF1/8"
	UNC 1/2	9	7				312-17	3404-216	W1/2"
	•UNC 9/16	10.5	8				•312-18	3404-217	M14, M15, W9/16"
	PT 1/8	8	6				312-19	3404-218	M11, W7/16, PS1/8", PF1/8", UNC7/16"
PT 1/4	11	9	312-20	3404-219	PS1/4, PF1/4				



Matching Size List



JIS SYSTEM SIZE

※ORDER NO. SAME COLOR ARE INTER-CHANGEABLE

1PC≒0.6kg

Size	Thread	Tap Shank		ØD1	L1	L2	ORDER NO.	CODE NO.	ØD x □ Size same as JIS inch or mm
		ØD	□						
TC 820 (#2)	M5 / M5.5	5.5	4.5	Suit for DIA. 31	36	30.5	820-00	3404-229	M5.5, W3/16"
	M6	6	4.5				820-00A	3404-228	W1/4", UNC1/4"
	M7	6.2	5				820-01	3404-230	M8
	M8	6.2	5				820-02	3404-231	M7
	M9	7	5.5				820-03	3404-232	M10, W3/8", UNC3/8"
	M10	7	5.5				820-04	3404-233	M9, W3/8", UNC3/8"
	M11	8	6				820-05	3404-234	W7/16", UNC7/16", PT1/8", PS1/8", PF1/8"
	M12	8.5	6.5				820-06	3404-235	
	M14	10.5	8				820-07	3404-226	M15, W9/16", UNC9/16"
	M15	10.5	8				820-08	3404-237	M14, W9/16", UNC9/16"
	M16	12.5	10				820-09	3404-238	
	M17	13	10				820-10	3404-239	
	M18	14	11				820-11	3404-240	W3/4", PT3/8", PS3/8", PF3/8", UNC3/4"
	M20	15	12				820-12	3404-241	
	M22	17	13				820-13	3404-242	W7/8", UNC7/8"
	UNC 3/8	7	5.5				820-14	3404-243	M9, M10, W3/8"
	UNC 7/16	8	6				820-15	3404-244	M11, W7/16", PT1/8", PS1/8", PF1/8"
	UNC 1/2	9	7				820-16	3404-245	W1/2"
	UNC 9/16	10.5	8				820-17	3404-246	M14, M15, W9/16"
	UNC 5/8	12	9				820-18	3404-247	W5/8"
	UNC 3/4	14	11				820-19	3404-248	M18, W3/4", PT3/8", PS3/8", PF3/8"
	UNC 7/8	17	13				820-20	3404-249	M22, W7/8"
	PT 1/8	8	6				820-21	3404-250	M11, W7/16", UNC7/16", PS1/8", PF1/8"
	PT 1/4	11	9				820-22	3404-251	PS1/4", PF1/4"
	PT 3/8	14	11				820-23	3404-252	M18, W3/4", PS3/8", PF3/8", UNC3/4"
PT 1/2	18	14	820-24	3404-253	PS1/2", PF1/2"				
M24	19	15	820-25	3404-254	M25, PF5/8"				

JIS SYSTEM SIZE

※ORDER NO. SAME COLOR ARE INTER-CHANGEABLE

1PC≒1.8kg

Size	Thread	Tap Shank		ØD1	L1	L2	ORDER NO.	CODE NO.	ØD x □ Size same as JIS inch or mm
		ØD	□						
TC 1433 (#3)	M14	10.5	8	Suit for DIA. 48	56	45	1433-01	3404-260	M15, W9/16", UNC9/16"
	M15	10.5	8				1433-02	3404-261	M14, W9/16", UNC9/16"
	M16	12.5	10				1433-03	3404-262	
	M17	13	10				1433-04	3404-263	
	M18	14	11				1433-05	3404-264	W3/4", UNC3/4", PT3/8", PS3/8", PF3/8"
	M20	15	12				1433-06	3404-265	
	M22	17	13				1433-07	3404-266	W7/8", UNC7/8"
	M24	19	15				1433-08	3404-267	M25, PF5/8"
	M25	19	15				1433-09	3404-268	M24, PF5/8"
	M26	20	15				1433-10	3404-269	M27, W1", UNC1"
	M27	20	15				1433-11	3404-270	M26, W1", UNC1"
	M28	21	17				1433-12	3404-271	
	M30	23	17				1433-13	3404-272	PT3/4", PS3/4", PF3/4"
	M32	24	19				1433-14	3404-273	W1-1/4", PF7/8", UNC1-1/4"
	M33	25	19				1433-15	3404-274	
	M34	26	21				1433-16	3404-275	M35, W1-3/8", PT1", PS1", PF1", UNC1-3/8"
	M35	26	21				1433-17	3404-276	M34, W1-3/8", PT1", PS1", PF1", UNC1-3/8"
	M36	28	21				1433-18	3404-277	
	UNC 9/16	10.5	8				V433-19	3404-278	M14, M15, W9/16"
	UNC 5/8	12	9				1433-20	3404-279	
	UNC 3/4	14	11				1433-21	3404-280	M18, W3/4", PT3/8", PS3/8", PF3/8"
	UNC 7/8	17	13				1433-22	3404-281	M22, W7/8"
	UNC 1	20	15				1433-23	3404-282	M26, M27, W1"
	UNC 1 1/8	22	17				1433-24	3404-283	
	UNC 1 1/4	24	19				1433-25	3404-284	M32, W1-1/4", PF7/8"
	UNC 1 3/8	26	21				1433-26	3404-285	M34, M35, W1-3/8", PT1", PS1", PF1"
	UNC 1/4	11	9				1433-27	3404-286	
	PT 3/8	14	11				1433-28	3404-287	M18, W3/4", PT3/8", PS3/8", PF3/8", UNC3/4"
	PT 1/2	18	14				1433-29	3404-288	
	PT 3/4	23	17				1433-30	3404-289	M30, PS3/4", PF3/4"
	PT 1	26	21				1433-31	3404-290	M34, M35, W1-3/8", PS1", PF1", UNC1-3/8"

TAPPING CHUCKS



Quick Change Tapping Collet



※ORDER NO. SAME COLOR ARE INTER-CHANGEABLE

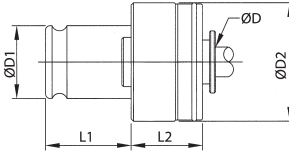

- Torque is factory-set to protect the tap for which a particular collet is designed. Small adjustments can be made by a trained user to accommodate tap strength and material variations.
- Collet stops driving when set torque is exceeded.
- Every tap needs a match size tapping collet.
- ØD1 is chuck suit for dia.

With Overload Safety Collet



DIN 371 Type

ORDER NO.	Size	TC312 DIN 371 Tap	Tap Shank		Capacity	L1 (m/m)	L2 (m/m)	ØD1 (m/m)	ØD2 (m/m)	CODE NO.	ØD x □ Size same as DIN 371
			ØD	□							
312-01D	TC 312 DIN 371	M1~M1.8	2.5	2.1	M1~M14	22.5	25	Suit for DIA. 19	32	3404-501	
312-02D		M2~M2.5	2.8	2.1						3404-502	M2,M2.5
312-02DA		M2	2.8	2.1						3404-502A	M2~M2.5,M2.5
312-02DB		M2.5	2.8	2.1						3404-502B	M2,M2~M2.5
312-03D		M3	3.5	2.7						3404-503	
312-04D		M3.5	4.0	3.0						3404-504	
312-05D		M4	4.5	3.4						3404-505	
312-06D		M4.5	6.0	4.9						3404-506	M5,M6
312-07D		M5	6.0	4.9						3404-507	M4.5,M6
312-08D		M6	6.0	4.9						3404-508	M4.5,M5
312-09D	M8	8.0	6.2	3404-509							
312-10D	M10	10.0	8.0	3404-510							
ORDER NO.	Size	TC820 DIN 371 Tap	Tap Shank		Capacity	L1 (m/m)	L2 (m/m)	ØD1 (m/m)	ØD2 (m/m)	CODE NO.	ØD x □ Size same as DIN 371
ØD	□										
820-01D	TC 820 DIN 371	M5	6.0	4.9	M5~M24	35	30.5	Suit for DIA. 31	50	3404-521	M6
820-02D		M6	6.0	4.9						3404-522	M5
820-03D		M8	8.0	6.2						3404-523	
820-04D		M10	10.0	8.0						3404-524	

DIN 376 Type

*Custom-build products are available on request.

ORDER NO.	Size	TC312 DIN 376 Tap	Tap Shank		Capacity	L1 (m/m)	L2 (m/m)	ØD1 (m/m)	ØD2 (m/m)	CODE NO.	ØD x □ Size same as DIN 376
			ØD	□							
312-21D	TC 312 DIN 376	M3.5	2.5	2.1	M3~M14	22.5	25	Suit for DIA. 19	32	3404-531	
312-22D		M4	2.8	2.1						3404-532	
312-23D		M4.5	3.5	2.7						3404-533	M5
312-24D		M5	3.5	2.7						3404-534	M4.5
312-25D		M6	4.5	3.4						3404-535	
312-26D		M7	5.5	4.3						3404-536	
312-27D		M8	6.0	4.9						3404-537	
312-28D		M10	7.0	5.5						3404-538	
312-29D		M12	9.0	7.0						3404-539	
312-30D		M14	11.0	9.0						3404-540	
ORDER NO.	Size	TC820 DIN 376 Tap	Tap Shank		Capacity	L1 (m/m)	L2 (m/m)	ØD1 (m/m)	ØD2 (m/m)	CODE NO.	ØD x □ Size same as DIN 376
ØD	□										
820-21D	TC 820 DIN 376	M8	6.0	4.9	M8~M24	35	30.5	Suit for DIA. 31	50	3404-551	
820-22D		M10	7.0	5.5						3404-552	
820-23D		M12	9.0	7.0						3404-553	
820-24D		M14	11.0	9.0						3404-554	
820-25D		M16	12.0	9.0						3404-555	
820-26D		M18	14.0	11.0						3404-556	
820-27D		M20	16.0	12.0						3404-557	
820-28D		M22	18.0	14.5						3404-558	M24
820-29D		M24	18.0	14.5						3404-559	M22
ORDER NO.	Size	TC1433 DIN 376 Tap	Tap Shank		Capacity	L1 (m/m)	L2 (m/m)	ØD1 (m/m)	ØD2 (m/m)	CODE NO.	ØD x □ Size same as DIN 376
ØD	□										
1433-01D	TC 1433 DIN 376	M14	11.0	9.0	M14~M36	55.5	45	Suit for DIA. 48	72	3404-571	
1433-02D		M16	12.0	9.0						3404-572	
1433-03D		M18	14.0	11.0						3404-573	
1433-04D		M20	16.0	12.0						3404-574	
1433-05D		M22	18.0	14.5						3404-575	M24
1433-06D		M24	18.0	14.5						3404-576	M22
1433-07D		M27	20.0	16.0						3404-577	
1433-08D		M30	22.0	18.0						3404-578	
1433-09D		M33	25.0	20.0						3404-579	
1433-10D		M36	28.0	22.0						3404-580	



Quick Change Tapping Collet



※ORDER NO. SAME COLOR ARE INTER-CHANGEABLE

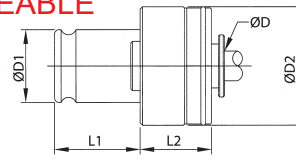

TC-312

With Overload Safety Collet

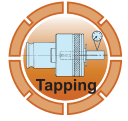

ISO 529/2283 Type

*Custom-build products are available on request.

ORDER NO.	Size	TC312 ISO 529/2283 Tap	Tap Shank		Capacity	L1 (m/m)	L2 (m/m)	ØD1 (m/m)	ØD2 (m/m)	CODE NO.	ØD x □ Size same as ISO 529
			ØD	□							
312-21I	TC 312 ISO 529/2283	M3	2.24	1.8	M3~M14	22.5	25	Suit for DIA. 19	32	3404-631	
312-22I		M3.5	2.5	2.0						3404-632	M1~M2, M2
312-23I		M4	3.15	2.5						3404-633	M3
312-24I		M4.5	3.55	2.8						3404-634	M3.5
312-25I		M5	4.0	3.15						3404-635	M4
312-26I		M6	4.5	3.55						3404-636	M4.5
312-27I		M7	5.6	4.5						3404-637	
312-28I		M8	6.3	5.0						3404-638	M6
312-29I		M9	7.1	5.6						3404-639	M7
312-30I		M10	8.0	6.3						3404-640	M8
312-31I		M12	9.0	7.1						3404-641	M9
312-32I		M14	11.2	9.0						3404-642	

ORDER NO.	Size	TC820 ISO 529/2283 Tap	Tap Shank		Capacity	L1 (m/m)	L2 (m/m)	ØD1 (m/m)	ØD2 (m/m)	CODE NO.	ØD x □ Size same as ISO 529 / 2283	ØD x □ Size same as ISO 529
			ØD	□								
820-21I	TC 820 ISO 529/2283	M8	6.3	5.0	M8~M24	35	30.5	Suit for DIA. 31	50	3404-651		M6
820-22I		M9	7.1	5.6						3404-652	M7	
820-23I		M10	8.0	6.3						3404-653	M8	
820-24I		M12	9.0	7.1						3404-654	M9	
820-25I		M14	11.2	9.0						3404-655		
820-26I		M16	12.5	10.0						3404-656		
820-27I		M18	14.0	11.2						3404-657	M20	
820-29I		M20	14.0	11.2						3404-658	M18	
820-30I		M22	16.0	12.5						3404-659		
820-31I		M24	18.0	14.0						3404-660		

ORDER NO.	Size	TC1433 ISO 529/2283 Tap	Tap Shank		Capacity	L1 (m/m)	L2 (m/m)	ØD1 (m/m)	ØD2 (m/m)	CODE NO.	ØD x □ Size same as ISO 529 / 2283
			ØD	□							
1433-01I	TC 1433 ISO 529/2283	M14	11.2	9.0	M14~M36	55.5	45	Suit for DIA. 48	72	3404-671	
1433-02I		M16	12.5	10.0						3404-672	
1433-03I		M18	14.0	11.2						3404-673	M20
1433-04I		M20	14.0	11.2						3404-674	M18
1433-05I		M22	16.0	12.5						3404-675	
1433-06I		M24	18.0	14.0						3404-676	
1433-07I		M27	20.0	16.0						3404-677	M30
1433-08I		M30	20.0	16.0						3404-678	M27
1433-09I		M33	22.4	18.0						3404-679	
1433-10I		M36	25.0	20.0						3404-680	

ISO 529 Type

ORDER NO.	Size	TC312 IOS 529 Tap	Tap Shank		Capacity	L1 (m/m)	L2 (m/m)	ØD1 (m/m)	ØD2 (m/m)	CODE NO.	ØD x □ Size same as ISO 529 / 2283	ØD x □ Size same as ISO 529
			ØD	□								
312-01I	TC 312 ISO 529	M1~M2	2.5	2.0	M1~M14	22.5	25	Suit for DIA. 19	32	3404-601	M3.5	M2
312-01IA		M2	2.5	2.0						3404-601A	M3.5	M1~M2
312-02I		M2.2~M2.5	2.8	2.24						3404-602		M2.5
312-02IA		M2.5	2.8	2.24						3404-602A		M2.2~M2.5
312-03I		M3	3.15	2.5						3404-603	M4	
312-04I		M3.5	3.55	2.8						3404-604	M4.5	
312-05I		M4	4.0	3.15						3404-605	M5	
312-06I		M4.5	4.5	3.55						3404-606	M6	
312-07I		M5	5.0	4.0						3404-607		
312-08I		M6	6.3	5.0						3404-608	M8	
312-09I		M7	7.1	5.6						3404-609	M9	
312-10I		M8	8.0	6.3						3404-610	M10	
312-11I		M9	9.0	7.1						3404-611	M12	
312-12I		M10	10.0	8.0						3404-612		

ORDER NO.	Size	TC820 ISO 529 Tap	Tap Shank		Capacity	L1 (m/m)	L2 (m/m)	ØD1 (m/m)	ØD2 (m/m)	CODE NO.	ØD x □ Size same as ISO 529 / 2283
			ØD	□							
820-01I	TC 820 ISO 529	M6	6.3	5.0	M6~M24	35	30.5	Suit for DIA. 31	50	3404-621	M8
820-02I		M7	7.1	5.6						3404-622	M9
820-03I		M8	8.0	6.3						3404-623	M10
820-04I		M9	9.0	7.1						3404-624	M12
820-05I		M10	10.0	8.0						3404-625	

TAPPING CHUCKS



Quick Change Tapping Collet



QUICK CHANGE TAP COLLETS

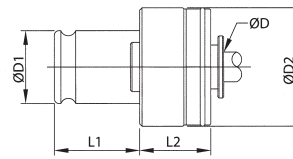

With Overload Safety Collet

ANSI TYPE

ORDER NO.	Size	TC312 ANSI Tap	Tap Shank				Capacity	L1 L2 (mm)	ØD1 ØD2 (mm)	CODE NO.	ØD x □ Size same as ANSI
			ØD		□						
			inch	mm	inch	mm					
TC312-#5-ANSI	TC312 ANSI	#5	0.141	3.581	0.11	2.794	#5~#14	21.5	Suit for DIA. 19.0	3404-701	UNC1/8",M3,M3.15
TC312-#6-ANSI		#6	0.141	3.581	0.11	2.794				3404-702	M3.5
TC312-#8-ANSI		#8	0.168	4.267	0.131	3.327				3404-703	UNC5/32",M4
TC312-#10-ANSI		#10	0.194	4.928	0.152	3.861				3404-704	UNC3/16",M4.5,M5
TC312-#12-ANSI		#12	0.220	5.588	0.165	4.191				3404-705	
TC312-#14-ANSI		#14	0.255	6.477	0.191	4.851				3404-706	UNC1/4",M6,M6.3
TC312-M3-ANSI		M3	0.141	3.581	0.11	2.794	M3~M14	25.0	32.0	3404-707	#5,UNC1/8",M3.15
TC312-M4-ANSI		M4	0.168	4.267	0.131	3.327				3404-708	#8,UNC5/32"
TC312-M5-ANSI		M5	0.194	4.928	0.52	3.861				3404-709	#10,UNC3/16",M4.5
TC312-M6-ANSI		M6	0.255	6.477	0.191	4.851				3404-710	#14,UNC1/4",M6.3
TC312-M8-ANSI		M8	0.318	8.077	0.238	6.045				3404-711	UNC5/16",M7
TC312-M10-ANSI		M10	0.323	8.204	0.242	6.147				3404-712	UNC7/16"
TC312-M12-ANSI		M12	0.367	9.322	0.275	6.985				3404-713	UNC1/2",M12.5
TC312-M14-ANSI		M14	0.429	10.897	0.322	8.179				3404-714	UNC9/16"
TC312-UNC1/8-ANSI		UNC1/8	0.141	3.581	0.11	2.794	UNC1/8 ~ UNC9/16	25.0	32.0	3404-715	#5,M3,M3.15
TC312-UNC3/16-ANSI		UNC3/16	0.194	4.928	0.152	3.861				3404-716	#10,M4.5,M5
TC312-UNC1/4-ANSI		UNC1/4	0.255	6.477	0.191	4.851				3404-717	#14,M6,M6.3
TC312-UNC5/16-ANSI		UNC5/16	0.318	8.077	0.238	6.045				3404-718	M7,M8
TC312-UNC7/16-ANSI		UNC7/16	0.323	8.204	0.242	6.147				3404-719	M10
TC312-UNC1/2-ANSI		UNC1/2	0.367	9.322	0.275	6.985				3404-720	M12,M12.5
TC312-UNC3/8-ANSI	UNC3/8	0.381	9.677	0.286	7.264	3404-721					
TC312-UNC9/16-ANSI	UNC9/16	0.429	10.897	0.322	8.179	3404-722				M14	

ANSI TYPE

ORDER NO.	Size	TC820 ANSI Tap	Tap Shank				Capacity	L1 L2 (mm)	ØD1 ØD2 (mm)	CODE NO.	ØD x □ Size same as ANSI
			ØD		□						
			inch	mm	inch	mm					
TC820-UNC7/16-ANSI	TC820 ANSI	UNC7/16	0.323	8.204	0.242	6.147	UNC7/16 ~ UNC7/8	35.0	Suit for DIA. 31.0	3404-731	M10
TC820-UNC1/2-ANSI		UNC1/2	0.367	9.322	0.275	6.985				3404-732	M12,M12.5
TC820-UNC3/8-ANSI		UNC3/8	0.381	9.677	0.286	7.264				3404-733	
TC820-UNC9/16-ANSI		UNC9/16	0.429	10.897	0.322	8.179	M6~M24	34.0	50.0	3404-734	M14
TC820-UNC5/8-ANSI		UNC5/8	0.480	12.192	0.36	9.144				3404-735	M16
TC820-UNC11/16-ANSI		UN11/16	0.542	13.767	0.406	10.312				3404-736	M18
TC820-UNC3/4-ANSI		UNC3/4	0.590	14.986	0.442	11.227				3404-737	
TC820-UNC13/16-ANSI		UNC13/16	0.652	16.561	0.489	12.421				3404-738	M20
TC820-UNC7/8-ANSI		UNC7/8	0.697	17.704	0.523	13.284				3404-739	M22



Quick Change Tapping Collet



QUICK CHANGE TAP COLLETS

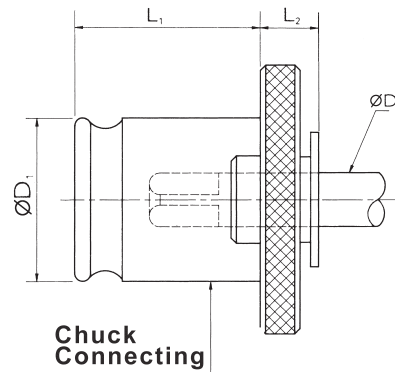

JIS SYSTEM SIZE

1PC ≅ 0.08kg

Size	Thread	Tap Shank		ØD1	L1	L2	ORDER NO.	CODE NO.	ØD x □ Same JIS inch or mm
		ØD	□						
TC312B (#1)	M3	4	3.2	Suit for DIA. 19	21.5	7	312B-01	3404-300	W1/8"
	M4	5	4				312B-02	3404-301	M4.5
	M5	5.5	4.5				312B-03	3404-302	M5.5, W3/16"
	M6	6	4.5				312B-04	3404-303	W1/4", UNC1/4"
	UNC 5/16	6.1	5				312B-05	3404-304	
	M7/M8	6.2	5				312B-06	3404-305	
	M9/M10	7	5.5				312B-07	3404-306	W3/8", UNC3/8"
	M11	8	6				312B-08	3404-307	W7/16", PT1/8", PS1/8", PF1/8", UNC7/16"
	M12	8.5	6.5				312B-09	3404-308	
	UNC 1/2	9	7				312B-10	3404-309	W1/2"
	M14	10.5	8				312B-11	3404-310	M15, W9/16"
	PT 1/4	11	9				312B-12	3404-311	PS1/4", PF1/4"

1PC ≅ 0.28kg

Size	Thread	Tap Shank		ØD1	L1	L2	ORDER NO.	CODE NO.	ØD x □ Same JIS inch or mm
		ØD	□						
TC820B (#2)	M7/M8	6.2	5	Suit for DIA. 31	35	11	820B-01	3404-330	
	M9/M10	7	5.5				820B-02	3404-331	W3/8", UNC3/8"
	M11	8	6				820B-03	3404-332	W7/16", UNC7/16", PT1/8", PS1/8", PF1/8"
	M12	8.5	6.5				820B-04	3404-333	
	UNC 1/2	9	7				820B-05	3404-334	W1/2"
	M14	10.5	8				820B-06	3404-335	M15, W9/16", UNC9/16"
	PT 1/4	11	9				820B-07	3404-336	PS1/4", PF1/4"
	UNC 5/8	12	9				820B-08	3404-337	W5/8"
	M16	12.5	10				820B-09	3404-338	
	M17	13	10				820B-10	3404-339	
	M18	14	11				820B-11	3404-340	W3/4", PT3/8", PS3/8", PF3/8", UNC3/4"
	M20	15	12				820B-12	3404-341	
	M22	17	13				820B-13	3404-342	W7/8", UNC7/8"
	PT 1/2	18	14				820B-14	3404-343	PS1/2", PF1/2"

1PC ≅ 0.8kg

Size	Thread	Tap Shank		ØD1	L1	L2	ORDER NO.	CODE NO.	ØD x □ Same JIS inch or mm
		ØD	□						
TC1433B (#3)	M14/M15	10.5	8	Suit for DIA. 48	55.5	14	1433B-01	3404-360	W9/16", UNC9/16"
	PT 1/4	11	9				1433B-02	3404-361	
	UNC 5/8	12	9				1433B-03	3404-362	
	M16	12.5	10				1433B-04	3404-363	
	M17	13	10				1433B-05	3404-364	
	M18	14	11				1433B-06	3404-365	W3/4", UNC3/4", PT3/8", PS3/8", PF3/8"
	M20	15	12				1433B-07	3404-366	
	M22	17	13				1433B-08	3404-367	W7/8", UNC7/8"
	PT 1/2	18	14				1433B-09	3404-368	
	M24/M25	19	15				1433B-10	3404-369	PF5/8"
	M26/M27	20	15				1433B-11	3404-370	W1", UNC1"
	M28	21	17				1433B-12	3404-371	
	UNC 1 1/8	22	17				1433B-13	3404-372	
	M30	22	18				1433B-14	3404-373	PT3/4", PS3/4", PF3/4"
	M32	24	19				1433B-15	3404-374	W1-1/4", PF7/8", UNC1-1/4"
	M33	25	20				1433B-16	3404-375	
	M34/M35	26	21				1433B-17	3404-376	W1-3/8", PT1", PS1", PF1", UNC1-3/8"
	M36	28	22				1433B-18	3404-377	PS1-1/8", PF1-1/8"



Tap Shank Dimensions INT. STD



For Tapping Chuck



JIS STANDARD

METRIC THREAD	INCH THREAD	Ød	□
M3	W 1/8	4	3.2
M4		5	4
M5		5.5	4.5
M6	W 1/4	6	4.5
	W 5/16	6.1	5
M8		6.2	5
M10		7	5.5
M11	W 7/16	8	6
M12		8.5	6.5
	W 1/2	9	7
M14		10.5	8
M15	W 9/16	12	9
	W 5/8	12	9
M16		12.5	10
M17		13	10
M18	W 3/4	14	11
M20		15	12
M22	W 7/8	17	13
M24		19	15
M25		19	15
M27	W1	20	15
M26		20	15
M28		21	17
	W 1-1/8	22	17
M30		23	17
M32	W1-1/4	24	19
M33		25	19
M35		26	21
M34	W1-3/8	26	21
M36		28	21
M38		28	21
M39		30	23
M40	W1-1/2	30	23
M42	W1-5/8	32	26
M45	W1-3/4	35	26
M48	W1-7/8	38	29

FOR TAP Thread	JIS Ød	JIS □	ISO Ød	ISO □	DIN 371 Ød	DIN 371 □	DIN 376 Ød	DIN 376 □
M3	4	3.2	3.15	2.5	3.5	2.7	2.2	-
M4	5	4	4	3.15	4.5	3.4	2.8	2.1
M5	5.5	4.5	5	4	6	4.9	3.5	2.7
M6	6	4.5	6.3	5	6	4.9	4.5	3.4
M8	6.2	5	8	6.3	8	6.2	6	4.9
M10	7	5.5	10	8	10	8	7	5.5
M12	8.5	6.5	9	7.1			9	7
M14	10.5	8	11.2	9			11	9
M16	12.5	10	12.5	10			12	9
M18	14	11	14	11.2			14	11
M20	15	12	14	11.2			16	12
M22	17	13	16	12.5			18	14.5
M24	19	15	18	14			18	14.5
M27	20	15	20	16			20	16
M30	23	17	20	16			22	18
PT 1/8	8	6						
PT 1/4	11	9						
PT 3/8	14	11						
PT 1/2	18	14						
PT 5/8	19	15						
PT 3/4	23	17						

DIN STANDARD

FOR TAP Thread	DIN 371 Ød	DIN 371 □	DIN 352 Ød	DIN 352 □	DIN 376 Ød	DIN 376 □
M1,M1.1,M1.2,M1.4,M1.6,M1.8	2.5	2.1	2.5	2.1		
M2,M2.2,M2.5	2.8	2.1	2.8	2.1		
M3	3.5	2.7	3.5	2.7	2.2	-
M3.5	4	3	4	3		
M4	4.5	3.4	4.5	3.4	2.8	2.1
M5,M6	6	4.9	6	4.9		
M8	8	6.2			6	4.9
M8			6	4.9	6	4.9
M10	10	8			7	5.5
M10			7	5.5	7	5.5
M12			9	7	9	7
M14			11	9	11	9
M16			12	9	12	9
M18			14	11	14	11
M20			16	12	16	12
M22,M24			18	14.5	18	14.5
M27			20	16	20	16
M30			22	18	22	18

DRILL HOLE SIZE FOR TAP THREAD

TAP THREAD	PITCH(P)	DRILL HOLE (d mm)
M1	0.25	0.75
M1.1	0.25	0.85
M1.2	0.25	0.95
M1.4	0.3	1.1
M1.6	0.35	1.25
M1.8	0.35	1.45
M2	0.4	1.6
M2.2	0.45	1.75
M2.5	0.45	2.05
M3	0.5	2.5
M3.5	0.6	2.9
M4	0.7	3.3
M4.5	0.75	3.75
M5	0.8	4.2
M6	1	5
M7	1	6
M8	1.25	6.75
M9	1.25	7.75
M10	1.5	8.5
M11	1.5	9.5
M12	1.75	10.2
M14	2	12
M16	2	14
M18	2.5	15.5
M20	2.5	17.5
M22	2.5	19.5
M24	3	21
M27	3	24
M30	3.5	26.5
M33	3.5	29.5
M36	4	32

FOR TAP Thread	JIS Ød	JIS □	ISO Ød	ISO □	DIN 371 Ød	DIN 371 □	DIN 376 Ød	DIN 376 □
W 1/8"	4	3.2						
W 3/16"	5.5	4.5						
W 1/4"	6	4.5						
W 5/16"	6.1	5						
W 3/8"	7	5.5						
W 7/16"	8	6						
W 1/2"	9	7						
W 5/8"	12	9						
W 3/4"	14	11						
W 7/8"	17	13						
W 1"	20	15						

JIS STANDARD PIPE THREAD

For Tap Style			Tapping Chuck Tap Size	
PT	PS	PF	Ød	□
1/8	1/8	1/8	8	6
1/4	1/4	1/4	11	9
3/8	3/8	3/8	14	11
1/2	1/2	1/2	18	14
		5/8	19	15
3/4	3/4	3/4	23	17
		7/8	24	19
1	1	1	26	21
	1 - 1/8	1 - 1/8	28	21
1 - 1/4	1 - 1/4	1 - 1/4	32	26
1 - 3/8	1 - 3/8	1 - 3/8	35	26
1 - 1/2	1 - 1/2	1 - 1/2	38	29