



ER Spring Collet Chuck System



Collet Holders With BT Taper Shank
(For CNC Machine Center)
ER-32 ER-40

MAS403 BT-SHANK



BT-40-ER32



BT-40-ER20M

ACCURACY
RUNOUT 0.005mm
TAPER SHANK AT-3
R.P.M. 7000

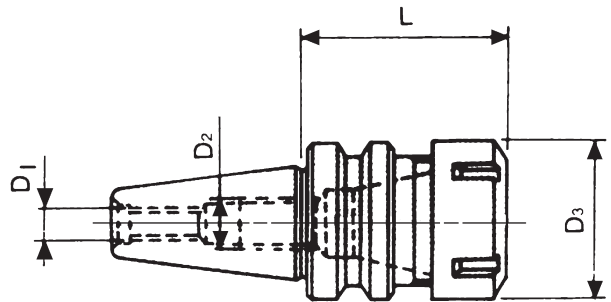

ER SYSTEM

ORDER NO.	TAPER	COLLET TYPE	D1	D2	D3	L	KGS	CODE NO.
V-700	BT30	ER32	M12	M12X1.75P	50	60	0.7	3031-303
V-703A	BT40	ER32	M16X2.0P	M22X1.5P	50	70	1.4	3032-305
V-703B		ER32	M16X2.0P	M22X1.5P	50	100	1.7	3032-306
V-704		ER40	M16X2.0P	M22X1.5P	63	80	1.7	3032-307
V-704B		ER40	M16X2.0P	M22X1.5P	63	100	2	3032-421
V-705	BT50	ER32	M24X3.0P	M28X1.5P	50	100	4.5	3033-305
V-706		ER40	M24X3.0P	M28X1.5P	63	100	4.6	3033-306
V-706B		ER40	M24X3.0P	M28X1.5P	63	150	5.7	3033-307
V-707		ER50	M24X3.0P	M36X1.5P	78	100	5.1	3033-308
V-710	BT30	ER11	M12	M12X1.75P	19	60	0.5	3033-311
V-711		ER11	M12	M12X1.75P	19	100	0.6	3033-312
V-712		ER11M	M12	M12X1.75P	16	100	0.9	3033-313
V-713		ER16	M12	M12X1.75P	28	100	0.8	3033-314
V-714		ER16M	M12	M12X1.75P	22	100	0.7	3033-315
V-715		ER20	M12	M12X1.75P	34	60	0.6	3033-316
V-716		ER20	M12	M12X1.75P	34	100	0.9	3033-317
V-717		ER20M	M12	M12X1.75P	28	100	0.9	3033-318
V-718		ER25	M12	M12X1.75P	42	60	0.7	3033-319
V-719		ER40	M12	M12X1.75P	63	70	1	3033-320
V-720	BT40	ER11	M16	M22X11.5P	19	70	1.2	3033-321
V-721		ER11	M16	M22X11.5P	19	100	1.5	3033-322
V-722A		ER11M	M16	M22X11.5P	16	100	1.05	3033-323
V-722B		ER11M	M16	M22X11.5P	16	150	1.3	3033-323A
V-723A		ER16M	M16	M22X11.5P	22	100	1.3	3033-324
V-723B		ER16M	M16	M22X11.5P	22	150	1.5	3033-330
V-724A		ER20M	M16	M22X11.5P	28	100	1.6	3033-325
V-724B		ER20M	M16	M22X11.5P	28	150	1.6	3033-331
V-725		ER25	M16	M22X11.5P	42	70	1.3	3033-326
V-726		ER25	M16	M22X11.5P	42	100	1.6	3033-327
V-727		ER50	M16	M22X11.5P	78	90	2.2	3033-328