



Tangimatic Dresser

ORDER NO.V-TDA CODE NO.2012-001

WEIGHT: 7 kgs

□ R:0-20
□ R:0-5
Center:40.02 mm

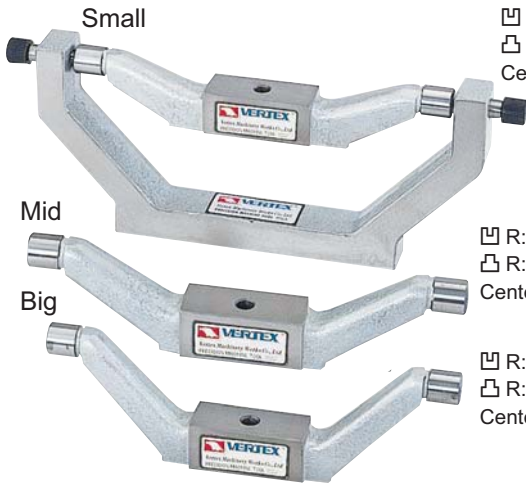

Mid

□ R:20-45
□ R:5-20
Center:53.88 mm

Big

□ R:45-90
□ R: 20-40
Center: 71.95 mm



The dresser can be dressing any concave and convex of grinding wheel $\lt; \varnothing 205 \text{ mm}$
Concave R: 0-40R (mm)
Convex R: 0-90R (mm)
Max. wheel DIA.: 8" (200 mm)
Diamond dresser pen 10 mm

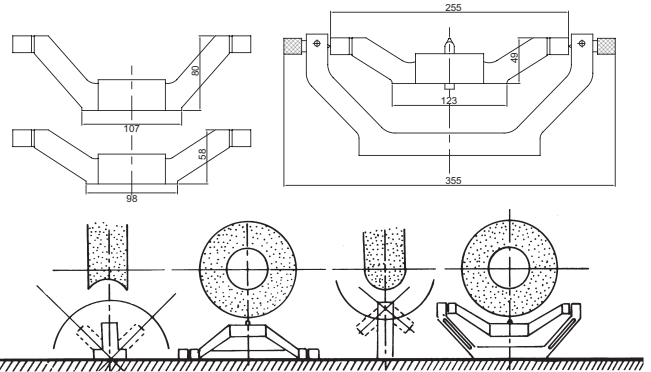

Tangimatic Dresser Handy Type

ORDER NO.V-TDH CODE NO.2012-002

WEIGHT:4.5 kgs

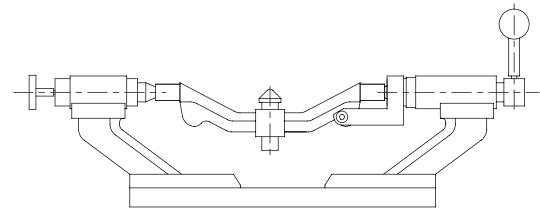
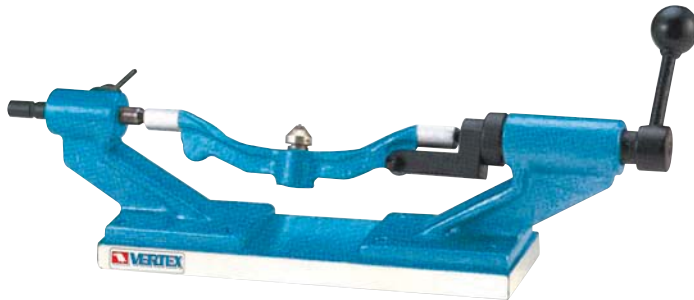

The dresser can be dressing any concave and convex of grinding wheel
Convex R: 0.2-20 (mm)
Concave R: 0.2-25 (mm)
For wheel $\lt; \varnothing 205 \text{ mm}$



Radius And Angle Dresser

ORDER NO.V-TDB CODE NO.2012-010

WEIGHT:11.5 kgs



Convex dressing range: 0.8R-40R
Concave dressing range: 0-40R
Max. wheel dressing diameter: 250 mm
Max. wheel extending diameter: 375 mm

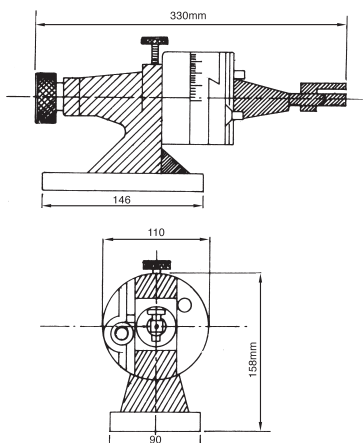

- Positive setting of the diamond to absolute center with the special gage included with the dresser.
- Simple, fast, accurate radius setting; no height gage or other set-up aids required. Radius is set on the grinder by measuring over the two pins or by inserting a gage block, as shown, for direct reading. Inside or outside radius is determined simply by sliding the dowel pin to the right for concave and to the left for convex.
- 4x90° graduation in full 360° circle. 6 Minute vernier reading. Chrome plated.
- One push-pull type knob for radius and angle control and for safer and faster operations.
- ACCURACY. Exteremely close tolerances are held in the manufacture of this tool, assured by hardening and precision grinding of all critical parts. Ways are chrome hardened.
- ECONOMY. Set-up and dressing time reduced to a bare minimum due to simplicity.



Universal Wheel Dresser



ORDER NO.V-TDC CODE NO.2012-020

WEIGHT:7.8kgs



The wheel dresser that dresses two angles tangent to a radius in one continuous motion with .0001~0.0002mm accuracy. The wheel dresser with a micrometer feed-0.98"(25mm) travel.

SIMPLE-ELIMINATES HIGHLY SKILLED OPERATORS

Fluidmotion means YOU CAN dress two angles tangent to a radius in one continuous motion-with only one setting. The diamond automatically returns to center position after dressing angles. Thus even a beginner can dress complex forms quickly and accurately. (center height 195mm)

ELIMINATES ELABORATE SETUPS

No need to pre-set diamond, or use any other tool except a micrometer and a simple hex wrench.

No Gage block-Master Gage setting or Block-Parallel Bar-Surface Plate-Height Gage-Dial Indicator.

No movement of dovetails necessary to form angles. The angle is dressed by continuing to push handle in both directions after radius is formed.

No need to use Gibs & V-Ways other than positioning surfaces.

ACCURATE-RAPID, REPEAT FORM-DRESSING

Fluidmotion generates clean, precise wheel profiles entirely free of chatter marks. Without fluidmotion a perfect blend of angles and radius is improbable.

PRECISE SHARP CONTOURS-concave or convex, at a full 180 degrees, are obtained consistently with (GUARANTEED) 0.001" accuracy.

CONVEX RANGE-0R-76.2R

CONCAVE RANGE-0.8R-88.9R

ACCURATE...FLUIDMOTION...PRECISE...

HOLD INTERSECTING ANGLES 12 to 15 seconds. This is accomplished by operating upright and handle.

Setting up two angles requires 10 seconds. Setting two angles and radius requires less than 3 minutes.

THE MOST DURABLE DRESSER AVAILABLE

Manufactured from hardened, ground and lapped alloy steels.

No wearing surfaces. Swivels on sealed bearings.

This form tangent in one setting-two angles-two radius-one flat.

MAX. Swing distance of diamond cutter.....±14mm

Measuring quasi-pin dia.....ø10

MAX. Wheel dia.....ø200mm

Reading accuracy of turret index.....5'

Feed per division of handle scale.....0.01mm

Calculation Method

To dress convex arc surface: $H=L + R$

To dress concave arc surface: $H=L +(-R)$

H: Distance between outer generating lines of two locating pins.

R: Radius of the arc surface to be dressed

L: Distance from tip of diamond cutter to base plate

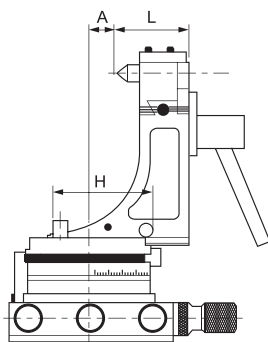
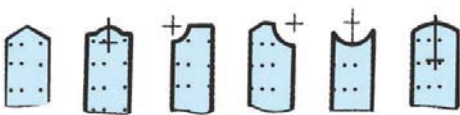
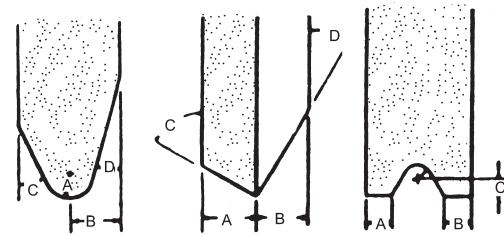
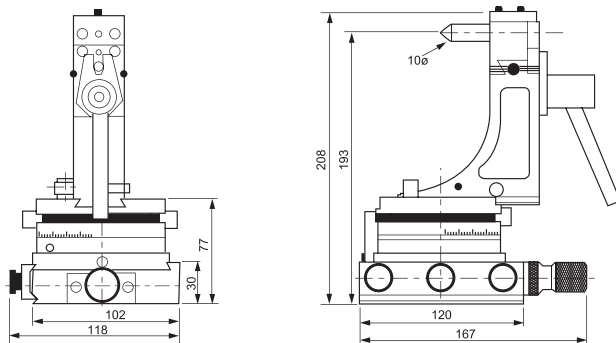

WHEEL DRESSER



Precision Duplex Dresser



ORDER NO.V-TDF CODE NO.2012-030

WEIGHT:3.7 kgs

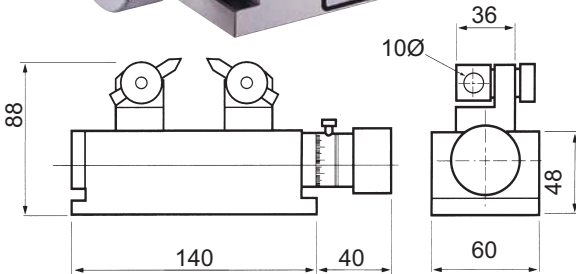

FEATURES

PRECISION DUPLEX DRESSER is designed to simultaneously dress both sides of a grinding wheel, precisely and without deformation. It is useful for the thinning of grinding wheels or the dressing of thin wheels. manufactured of tool steel and hardened through out to HRC 60 for life time use.

Specifications:

- Max. width of wheel.....40 mm (1-9/16")
- Max. dressing depth.....40 mm (1-9/16")
- Mini dressing width.....0.2 mm (0.0079")
- Graduation.....0.02 mm (0.0001")

Max.thickness	Min.	Max.	Min
40mm	0.2mm	40mm	0.02mm/div



Radius And Angle Dresser

ORDER NO.V-TDG CODE NO.2012-040

WEIGHT:12 kgs

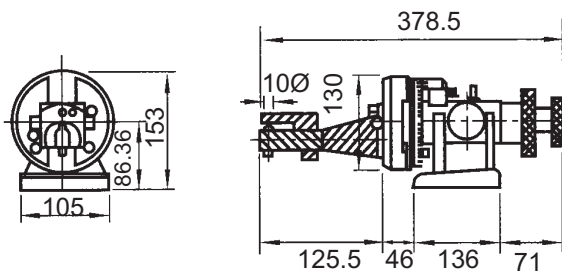
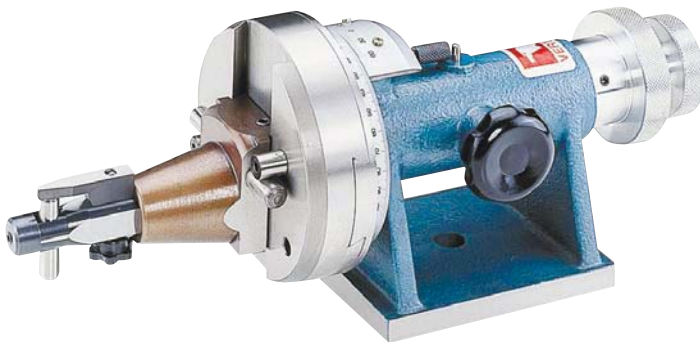

FEATURES

- 6 minute vernier reading.
- 5-1/2" long x 6-1/2" high.
- Dual purpose knob for drum & angle movement.
- Stop for concave and convex radius.
- Comes with setting gage for diamond tool.
- □ R CONCAVE = 150 mm
- □ CONVEX = 60 mm
- MAX. Wheel Dia = 279.4 mm
- Left & Right Stroke = 90 mm

Specifications:

Max. wheel diameter, standard.....	11"
Concave radius with standard diamonds.....	0-2 1/4"
Concave radius with rta-tail diamonds.....	0-2 1/4"
Convex radius.....	0-4"
Tangent travel in either direction.....	1.950"
Center line.....	3.4"



Radius And Angle Dresser

ORDER NO.V-TDE CODE NO.2012-050

WEIGHT:9.2 kgs

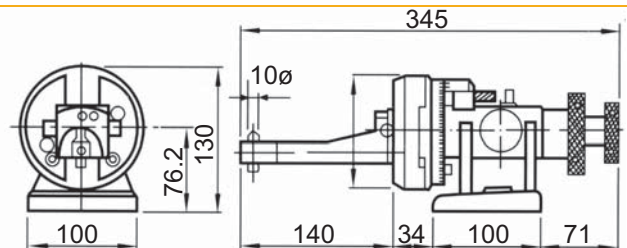

Features

- No height gauge or set-up aids required.
- Radius is set on the grinder by measuring over the two pins or by inserting a gauge block for direct reading.
- Concave radius or Convex radius is determined by using either the left or right hand pins.
- Radius = Set the DRESSER on surface grinder measuring by the 2 pins and / or inserting gauge block for direct reading.

Grinding wheel dressing application

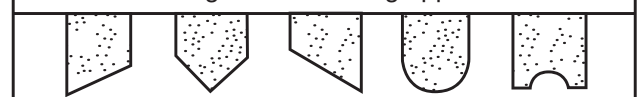

- □ R CONCAVE = 100 mm
- □ CONVEX = 45 mm
- Left & Right Stroke = 65 mm



Optical Radius Angle Dresser



ORDER NO.V-TDT CODE NO.2012-060

WEIGHT:4.3 kgs

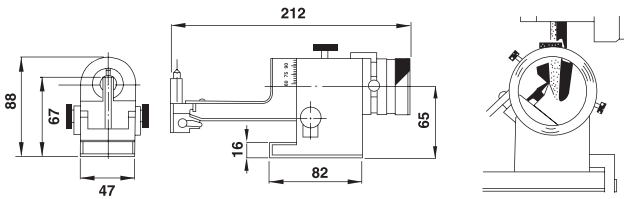

Features

Universal Wheel Dresser is Adoptable on Surface grinder and universal tool grinder for dressing grinding wheel into various cross sections of flat or curved shapes. By "SIGHTING" the diamond point through the lens, radius and angles can easily be made perfectly tangent Visually Even with diamonds. Likewise radius can be blended together with most unbelievable accuracy.

Specification

Center height.....65 mm
Max. wheel diameter.....200 mm
Max. convex radius.....10 mm
Max. concave radius.....25.4 mm
Dressing angle.....95°-0°-95°
Tangential travel.....Appo x 22.5 mm

Grinding wheel dressing application



WHEEL DRESSER



Matco Sine Dresser

ORDER NO.VP-50 CODE NO.2012-070

WEIGHT:2.5 kgs



- This fine precision-made unit dresses grinding wheels to any angle from 0°-60° degrees with new smoothness and accuracy.
- The cross feed up to 50mm, center distance 0.01 mm, Sine angle absolutely accurate.

DRESSER

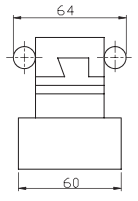
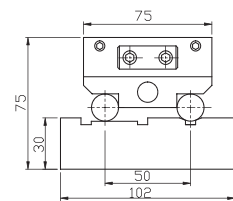
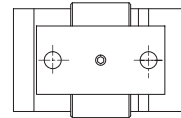
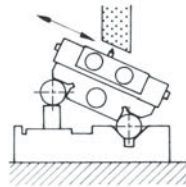

SPECIFICATION

BLOCK CENTER DISTANCE	CENTER TOLERANCE	MAX CROSS FEED
50	±0.01	50



Matco Sine Dresser

ORDER NO.V-50D CODE NO.2012-080

WEIGHT:1.6 kgs



This fine precision-made unit dresses grinding wheels to any angle from 0°-60° degrees with new smoothness and accuracy.

The cross feed up to 50 mm, center distance 0.01 mm, Sine angle absolutely accurate.

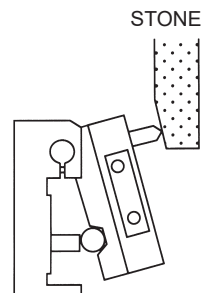
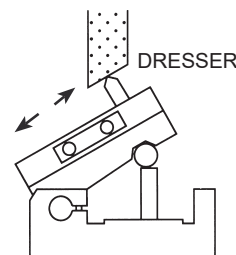
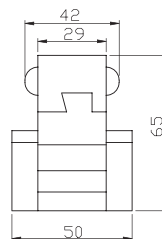
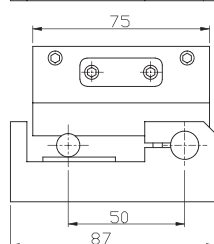
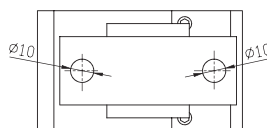



Diamond Wheel Dresser

ORDER NO.V-TDD

CODE NO.2012-090

WEIGHT:4.6 kgs

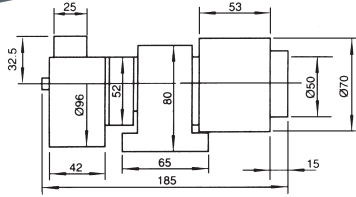

This device is suitably used for Diamond Grinding wheel. The surface is treated with blaze-dried lacquer.

Axis part is fixed with shaft bearing and can be rotated in high speed & with great precision.

- Sand wheel size: Ø75 x 26 x 12.7 ØWA80
- ✳ No motor



Motor Type CBN Flat Wheel Dresser

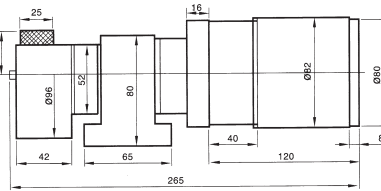

Unit: mm

ORDER NO.	VOLTAGE	RPM	WEIGHT (kgs)	CODE NO.
V-TDM-1	110V	129	6.5	2012-100
V-TDM-2	220V	108	7.1	2012-101

5.5KGS, SINGLE PHASE

0.07HP

SAND WHEEL SIZE: Ø75 x 25 x 12.7 ØWA80



Parallel Wheel Dresser

ORDER NO.V-TDP

CODE NO.2012-106

WEIGHT:7.7kgs

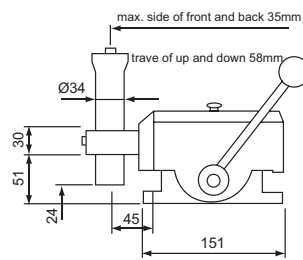
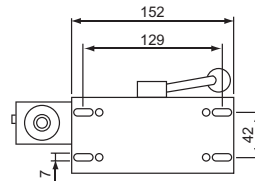

- Smallest feed scale : 0.01 mm
- Slide movement 35 mm
- Axial movement 58 mm
- For dress / fix the flat shape grinding wheel.
- Heat hardened, HRC 58°
- Smooth movement

Accessory :

- Diamond pen : Ø10 x 35ℓ x 1
- Hex. spanner 5 mm x 1



Wheel Hanger

ORDER NO.VWH-24, VWH-32

CODE NO.2013-001, 2013-002

WEIGHT:23.1 kgs

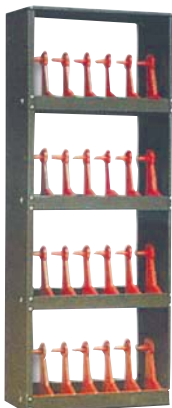

VWH-24 (24 pcs)



VWH-32 (32 pcs)
653W x 600D x 1460H mm
(excl. wheel height)

