



Punch Former



ORDER NO. V-PS
CODE NO. 2001-010

1 WAY Ø30 THROUGH HOLE

Specification

D(diameter)of the pressed part of the punch...4-30mm
L(length)of the pressed part of the punch...above22mm
Upper and lower movement span of V block.....25mm
Horizontal movement span of V block(one side)..12.5mm
(tow side)...25mm

Length of V block30mm
Height of the rotary central axis.....15mm
Cutting and dividing.....24 equal pieces(15")
Sand forming of the forming lever
(concave R).....100mmR
(convex R).....48mmR
Diamond sharpening knife : (small diameter)60x50(1/10carat)
(large diameter)100x50(1/4carat)

*Except for the handle and graduation scale all metal is special hard tool steel (SKS-2) heat treated at HRC 63

*V block can be disassembled for use separately.

V-PS the center through hole is ø30mm

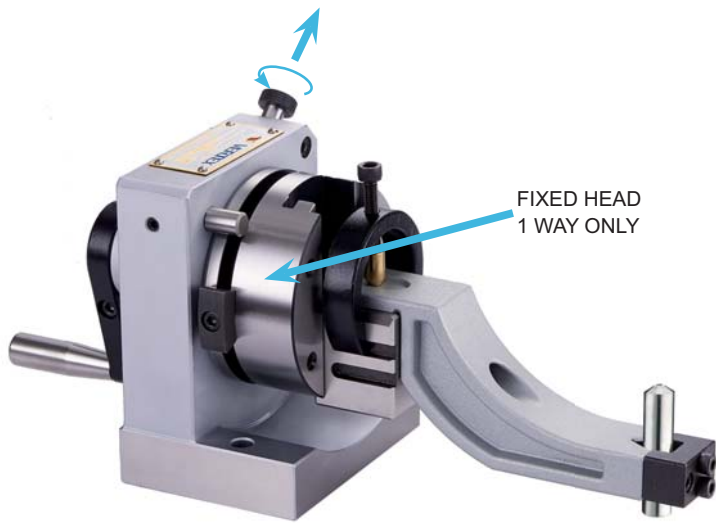

PUNCH FORMER

V-PS allows go through from the center of grip, to clamp a more longer punch ejector pin, it can go deep into of the grip position directly. To assemble an ARM with the main body, any combination of radial form of the grinding wheel may be dressed accurately by easy operation.

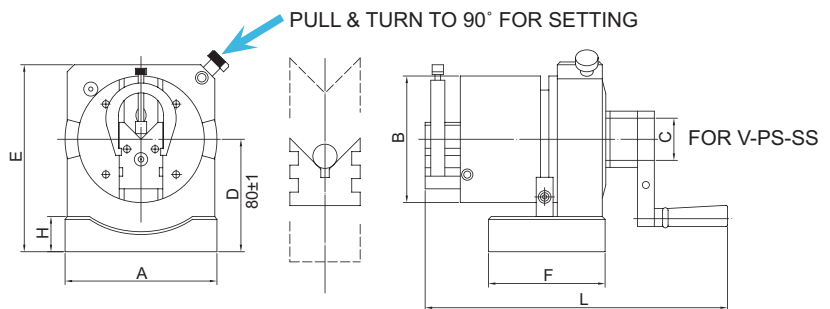

ORDER NO.	A	B	C	D	E	F	H	L	WEIGHT (kgs)	CODE NO.
V-PS	108	Ø90	Ø30	80-81	133	83	25	197	8.7	2001-010

Application grinding wheel style:

FOR INJECTOR PIN

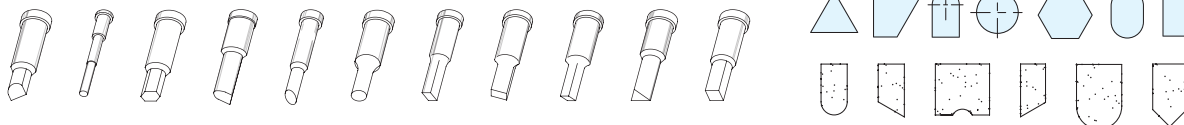

Special Part Accessory For Angular Dressing

ORDER NO.V-PF CODE NO.2001-020
Without Diamond WEIGHT: 0.7KG

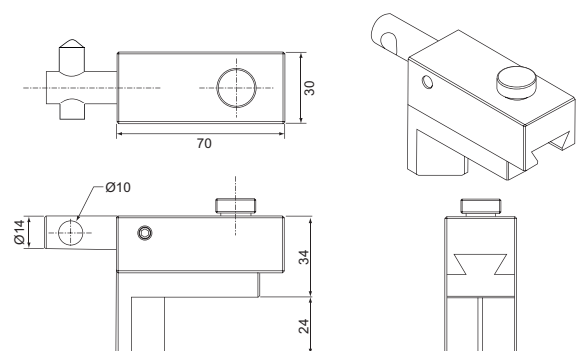
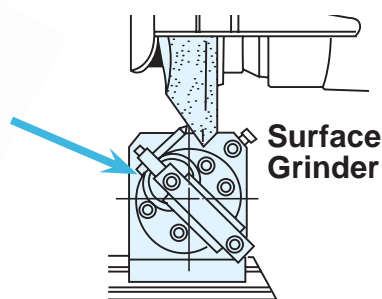

The Wheel angular dressing