

Punch Grinder

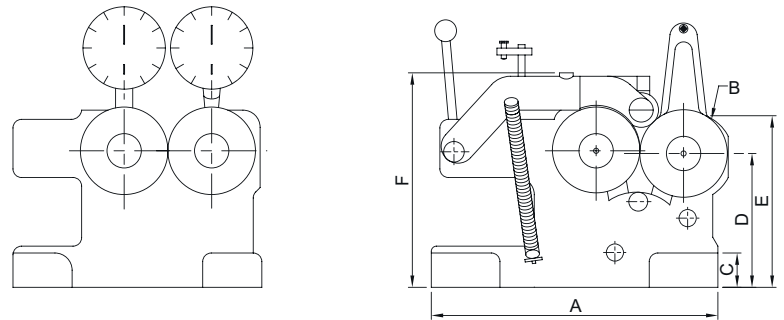

ORDER NO.V-PGS CODE NO.2002-001
 MINI-TYPE PUNCH GRINDER Ø1.5-3mm

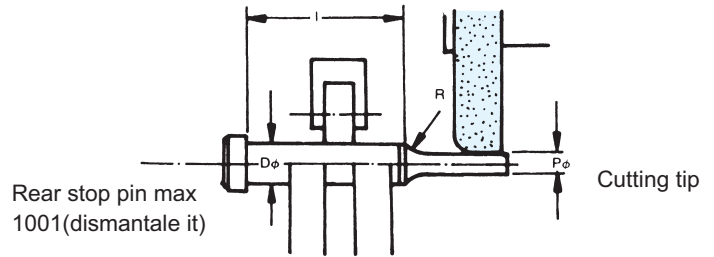

This is a mini type punch grinder which can grind fine punch of outside diameter from 1.5mm to 3mm.
 N.W.4.5kgs
 Accuracy of point A within 0.005mm and point B Within 0.008mm while turning.

ORDER NO.	A	B	C	D	E	F	WEIGHT (kgs)	CODE NO.
V-PGS	167	Ø51	20	78	100	125	4.5	2002-001

Punch Grinder

ORDER NO.V-PG CODE NO.2002-010
 STANDARD-TYPE Ø1.5-Ø25 WEIGHT: 6.6kgs

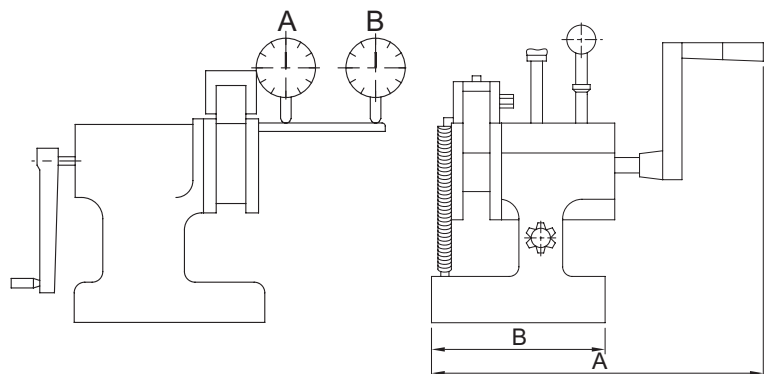

Punch grinder is a tool which can be put on the surface plate of grinding machine for round punches(1.5mm-25mm). It can be ground by putting among three rollers of punch grinder. without checking the center.
 Accuracy of roller within 0.005mm while turning right or left. It can allow lenth 5-35mm
 Accuracy of point A within 0.005mm and point B Within 0.008mm while turning.

ORDER NO.	A	B	WEIGHT (kgs)	CODE NO.
V-PG	172	90	6.6	2002-010

Punch Grinder



ORDER NO.V-PGM CODE NO.2002-020

WITH MOTOR TYPE Ø1.5 - Ø25

WEIGHT: 11.8 kgs

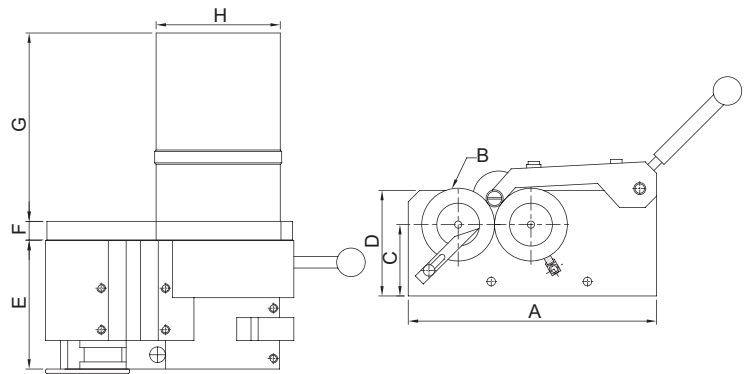

Features

- 1.High accuracy cylindrical grinding work is possible, just putting this economical unit on surface grinder.
- 2.No center alignment necessary. just put work piece on rollers.
- 3.Portable with single hand, thus easily set up.
- 4.With rollers motor -driven, attention can be concentrated on table/wheel feeds.
- 5.Work can be formed in radius taper as well
- 6.Double roller unit available for long pin or punch grinding.

FEATURES

- Mounting surface(RLxFB).....175 X 218 X 90 mm
 - 50Hz/220v.....108 rpm
 - Roller speed 60Hz/110v.....129 rpm
 - Accuracy(Roundness and concentricity).....25.4 mm
 - Roller driving motor 110v, Single phase, 25W
- (Specifications are subject to change without notice.)

ORDER NO.	A	B	C	D	E	F	G	H	WEIGHT (kgs)	CODE NO.
V-PGM	174	Ø51	50	74	90	13	132	87	11.8	2002-020

Punch Grinder

ORDER NO:V-PGA CODE NO.2002-030 WEIGHT:3.1kgs



- Grinding Max. Length 30 mm
- Grinding Max. Length 9 mm

Ø0.5~Ø10

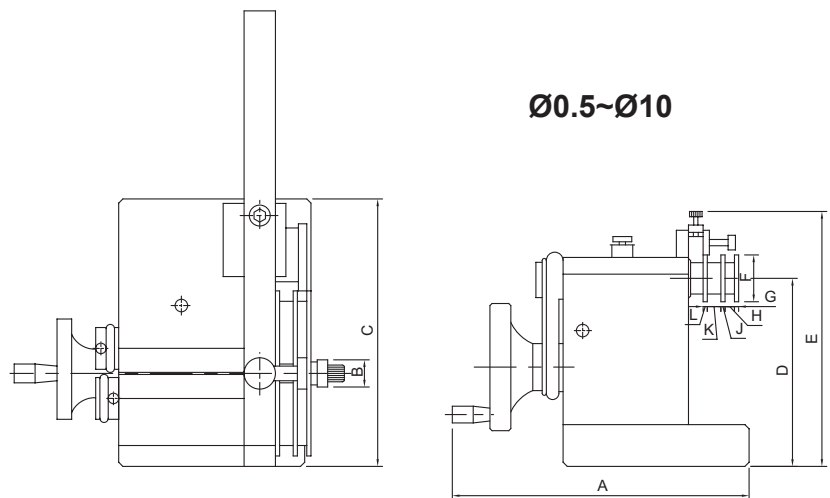

1. The small punch grinder can process from dia Ø0.5 mm to 6 mm. Smallest workpiece length : 10 mm
This punch grinder can work with surface grinding machine and to grinding any sizes.
2. Easy operation and high precision make it to be the best grindig tool for small workpiece.

ORDER NO.	A	B	C	D	E	F	G	H	J	K	L	WEIGHT (kgs)	CODE NO.
V-PGA	142	Ø13	128	90	122	22.4	2	4.5	2	6.5	2	3.1	2002-030