



Height
Gage Block
PAGE B76

● Example

- Compound angles easily and quickly set.
- Adjustments up to 46 degrees.

Accuracy :

Material Hardened: SKS HRC 60° Sub-zero processing.

Parallelism: Within 0.003 / 100 mm

Squareness: Within 0.005 / 100 mm

Angle tol: Within 15 sec Within 20 sec

*Sine conversion table attached page B16

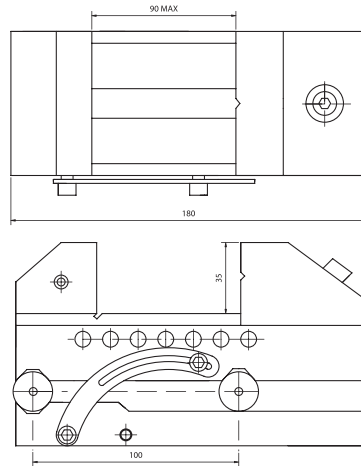

SPECIFICATION

Unit:mm

ORDER NO.	MATERIAL	LENGTH	WIDTH	JAW OPENING	JAW HEIGHT	HEIGHT (mm)	ANGLE	HARDEN	N.W (KGS)	CODE. NO.
SVB-20	SK2	155	48	80	30	93.5	0°-46°	HRC56°-58°	4.4	2003-030
SVB-25	SK2	175	63	90	35	102.5	0°-46°	HRC56°-58°	6	2003-031
SVB-30	SK2	180	73	90	35	103.8	0°-46°	HRC56°-58°	6.9	2003-032



Height
Gage Block
PAGE B76

● Example

- Compound angles easily and quickly set.
- Adjustments up to 46 degrees.

Accuracy :

Material Hardened: SKS HRC 60° Sub-zero processing.

Parallelism: Within 0.003 / 100 mm

Squareness: Within 0.005 / 100 mm

*Sine conversion table attached page B16

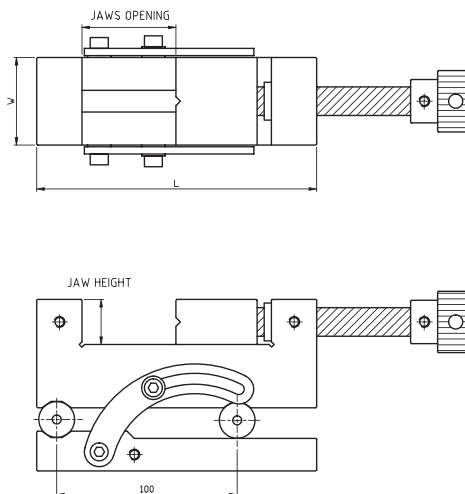

SPECIFICATION

Unit:mm

ORDER NO.	MATERIAL	LENGTH	WIDTH	JAW OPENING	JAW HEIGHT	HEIGHT (mm)	ANGLE	HARDEN	N.W (KGS)	CODE. NO.
SVD-200	SK2	155	48	60	25	94	0°-46°	HRC54°±2	4.6	2003-040
SVD-250	SK2	176	63	68	30	97.5	0°-46°	HRC54°±2	6.4	2003-041
SVD-300	SK2	180	73	72	30	103	0°-46°	HRC54°±2	8.4	2003-042