

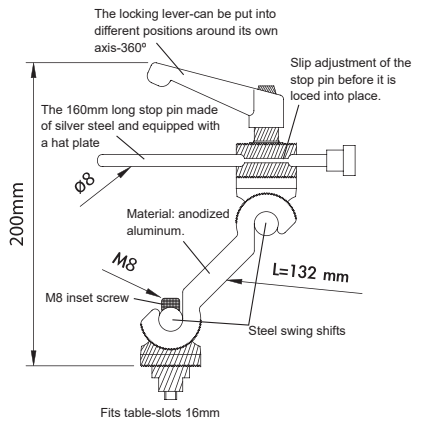

**NON TEETH TYPE**  
**ORDER NO. VWS-123**  
**CODE NO. 1002-105**  
**WEIGHT: 0.9kg**  
**T-SLOT: 16mm**

**TEETH TYPE**  
**ORDER NO. VWS-125**  
**CODE NO. 1002-106**  
**WEIGHT: 1.1kg**  
**T-SLOT: 16mm**

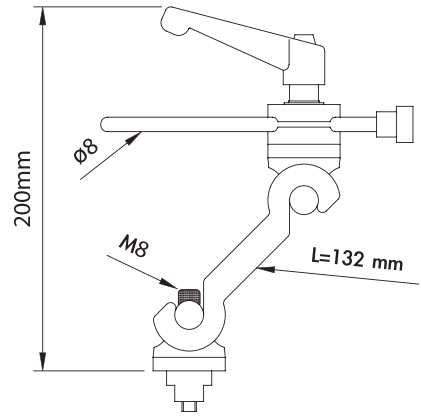

ORDER NO.	CODE NO.
VWS-123	1002-105
VWS-125	1002-106

- It is fixed and secured by its rigid serration without skid. (300kg bump is permanent)

## T Slot Clamps

PATENT

For Thin Work Piece

**NEW**

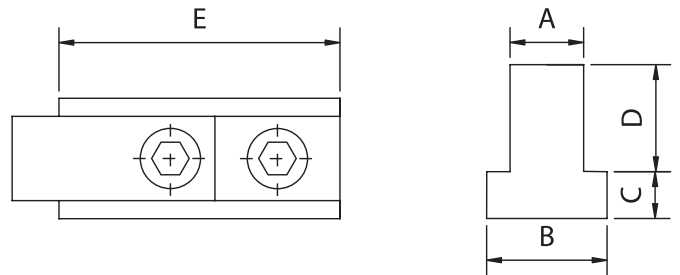

- 1 Set consist of 4 vices.
- For thin or small workpiece.
- Good clamping force.
- Quick setting
- Suit for light duty cutting on the milling drilling / EDM machine.



ORDER NO.	A	B	C	D	E	N.W.	CODE NO.
CK-3712	11.5	18	7	16	42	0.6	1002-311
CK-3714	13.5	22	8	18	42	0.7	1002-312
CK-3716	15.5	25	10	20	45	0.9	1002-313
CK-3718	17.5	28	11	24	45	1.1	1002-314
CK-3720	19.5	32	12	26	53	1.5	1002-315