

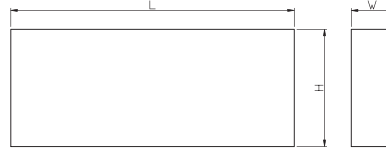

Ground Parallels

ORDER NO.VP-100 CODE NO.1004-001

To provide more convenient processing for milling vise.



- Hardness: HRC 48°-53°
- Accuracy: 0.01mm
- Process: Four-side ground
- 1 set includes 18 pcs
- Packed by plastic case, G.W.: 11.7 kgs, Meas: 0.3 CFT.
- Dimension: 390x292x84mm

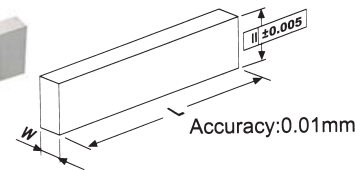

Unit:mm

BODY SIZE	CLAMP SIZE
WxHxLxPcs	AxBxCxLxPcs
5x16x100x2	15x31x2.5x200x2
6x18x100x2	
8x24x100x2	
10x30x100x2	
12x36x150x2	
14x48x150x2	
18x60x150x2	
22x62x150x2	



Ground Parallels

ORDER NO.VP-118A CODE NO.1004-010

8.5mm WIDTH, 5.8kgs

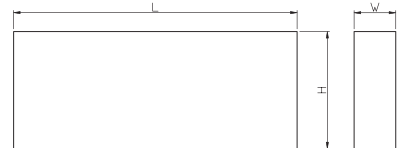

Unit:mm



- Hardness: HRC 48°-53°
- MADE OF HIGH GRADE ALLOY STEEL HARDENED AND GROUND.
- Dimension: 290x228x80mm

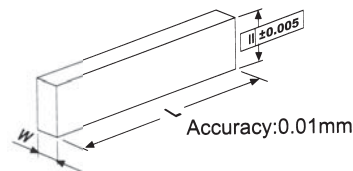

WxHxLxPcs	
8.5x14x150x2	8.5x32x150x2
8.5x16x150x2	8.5x36x150x2
8.5x20x150x2	8.5x40x150x2
8.5x24x150x2	8.5x44x150x2
8.5x30x150x2	



Ground Parallels

ORDER NO.VP-128A CODE NO.1004-020

28 PCS/SET 10.7kgs

VP-128A 10mm WIDTH

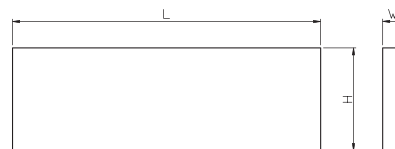

- Hardness: HRC 48°-53°
- MADE OF HIGH GRADE ALLOY STEEL HARDENED AND GROUND.
- Dimension: 390x292x82mm

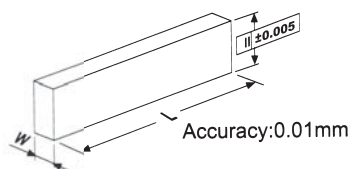

Unit:mm

WxHxLxPcs	
10x14x150x2	10x28x150x2
10x16x150x2	10x30x150x2
10x18x150x2	10x32x150x2
10x20x150x2	10x35x150x2
10x22x150x2	10x40x150x2
10x24x150x2	10x45x150x2
10x26x150x2	10x50x150x2



Precision Parallels

ORDER NO.VP-136 CODE NO.1004-030

To provide more convenient processing for milling vise

- Hardness: HRC 48°-53°



ACCURACY:0.01mm

WIDTH 8.0mm

36 PCS/SET 12.3kgs

Unit:mm

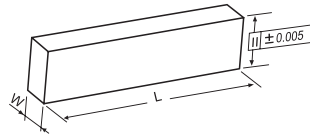
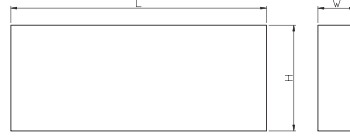

WxHxLxPcs	
8x16x150x2	8x34x150x2
8x18x150x2	8x36x150x2
8x20x150x2	8x38x150x2
8x22x150x2	8x40x150x2
8x24x150x2	8x42x150x2
8x26x150x2	8x44x150x2
8x28x150x2	8x46x150x2
8x30x150x2	8x48x150x2
8x32x150x2	8x50x150x2

- Dimension: 390x292x82mm



VP-018 Thin Type Parallels Set

ORDER NO.VP-018 CODE NO.1004-040

3Wx150Lx20 PCS/SET

- Hardness: HRC 48°-53°

G.W. 2.5kgs.

ACCURACY: 0.01mm

THICKNESS 1/8" ≒ 3mm

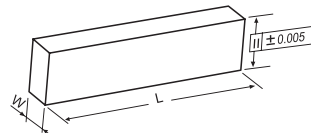
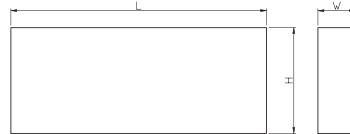

WxHxLxPcs	WxHxLxPcs
3x13x150x2	3x28x150x2
3x16x150x2	3x31x150x2
3x19x150x2	3x35x150x2
3x22x150x2	3x38x150x2
3x25x150x2	3x41x150x2

- Dimension: 290x230x73mm



VP-163 Precision Parallels

ORDER NO.VP-163 CODE NO.1004-050

5Wx150Lx8 PCS/SET

- Hardness: HRC 48°-53°

G.W. 1.7kgs.

ACCURACY: 0.01mm

THICKNESS 3/16" ≒ 5mm

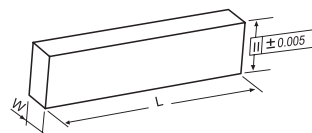
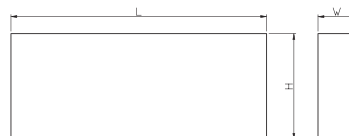

WxHxLxPcs
5x25x150x2
5x31x150x2
5x38x150x2
5x44x150x2

- Dimension: 175x85x55mm



VP-064 Precision Parallels



ORDER NO.VP-064 CODE NO.1004-060

6Wx150Lx18 PCS/SET

- Hardness: HRC 48°-53°

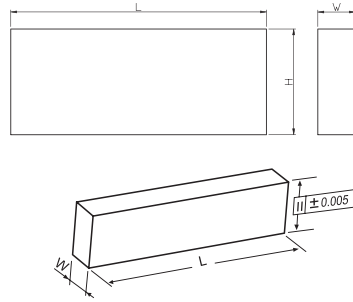

G.W. 4.5kgs.
ACCURACY: 0.01mm
THICKNESS 1/4" \approx 6mm

WxHxLxPcs	WxHxLxPcs
6x19x150x2	6x35x150x2
6x22x150x2	6x38x150x2
6x25x150x2	6x41x150x2
6x28x150x2	6x44x150x2
6x31x150x2	

- Dimension: 288x228x75mm



VP-050 Precision Parallels

ORDER NO.VP-050 CODE NO.1004-070

13Wx150Lx8 PCS/SET

- Hardness: HRC 48°-53°

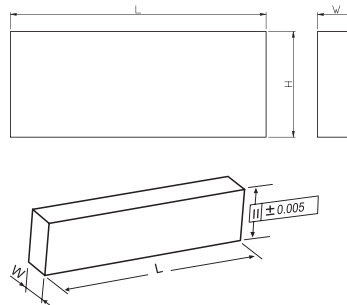

G.W. 4.5kgs.
ACCURACY: 0.01mm
THICKNESS 1/2" \approx 13mm

WxHxLxPcs
13x25x150x2
13x31x150x2
13x38x150x2
13x44x150x2

- Dimension: 175x150x55mm



VP-033 Precision Parallels

ORDER NO.VP-033 CODE NO:1004-080

200Lx8 PCS/SET
Accuracy: 0.01 mm

- Hardness: HRC 48°-53°

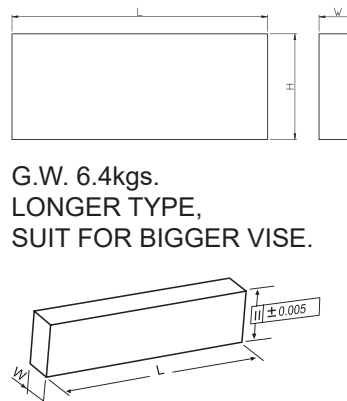

G.W. 6.4kgs.
LONGER TYPE,
SUIT FOR BIGGER VISE.

WxHxLxPCS
8x24x200x2
12x36x200x2
22x40x200x2
31x15x200x2x2.5 For Clamping
15x31x2.5x200x2

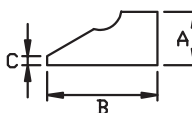

- Dimension: 340x223x85mm



VP-146 Ground Parallels

ORDER NO.VP-146 CODE NO:1004-082

4.6Wx150Lx12 PCS/SET

Accuracy: 0.01 mm



GROUND PARALLELS

NEW

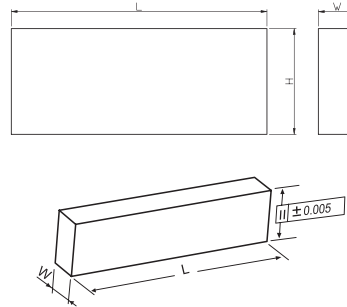

G.W. 3kgs.
Material: S45C
Hardness: HRC48°-53°

WxHxLxPCS
4.6x32x150x2
4.6x34x150x2
4.6x36x150x2
4.6x38x150x2
4.6x40x150x2
4.6x44x150x2

● Dimension: 195x180x90mm



VP-168 Ground Parallels

ORDER NO.VP-168 CODE NO:1004-083

6.8Wx150Lx14 PCS/SET

Accuracy: 0.01 mm

NEW

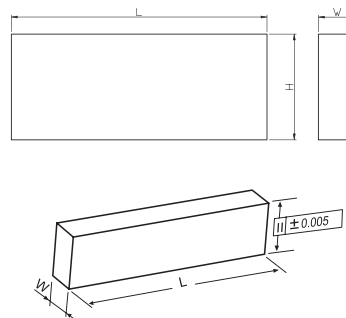

G.W. 3.5kgs.
Material: S45C
Hardness: HRC48°-53°

WxHxLxPCS
6.8x15x150x2
6.8x18x150x2
6.8x21x150x2
6.8x25x150x2
6.8x27x150x2
6.8x31x150x2
6.8x35x150x2

● Dimension: 225x200x90mm



VP-200 Ground Parallels

ORDER NO.VP-200 CODE NO.1004-085

NEW

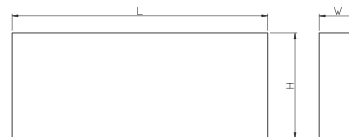

MADE OF HIGH GRADE
ALLOY STEEL
HARDENED AND
GROUND.
ACCURACY: 0.01/100 MM
G.W. :15.6 KGS

● Hardness: HRC 48°-53°

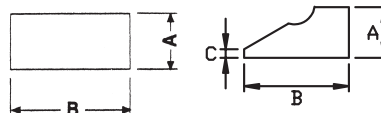

FOR OVER 150 mm, 200mm
JAW PLATE VISE USING

● Dimension: 355x318x85mm

BODY SIZE	CLAMP SIZE
AxBxLxPcs	AxBxCxLxPcs
5x16x150x2	31x15x200x2x2.5
6x18x150x2	
8x24x150x2	
10x30x150x2	
12x36x200x2	
14x48x200x2	
18x60x200x2	
22x62x200x2	