



NC Hydro Machine Vices



PATENT

SAME HEIGHT GUARANTEE

NEW



COMPARE WITH SAME WIDTH VISE JAW, VNC TYPE HAS THE BIGGEST OPENING CAPACITY.

Features

- Hydro-booster system for maximum clamping pressure with minimum force.
- Sliding bed ways flame hardened and ground.
- Compact design. Great clamping capacity. Light & smooth operation.
- Body is made of FCD60 ductile cast iron, High deflection/bending resistant.
- Constructed for machining center, milling, drilling, grinding and many other machine shop applications.
- Hydro line - one scale indicate about 1/3 of the max. clamp force.





NC Hydro Machine Vices

PATENT

SAME HEIGHT GUARANTEE



NC HYDRO MACHINE VISE

Hydraulic controller:
provide stable pressure,
Hydro indexer. Protect the hydro system.
Hydro limit proof reference scale.



Accessories:

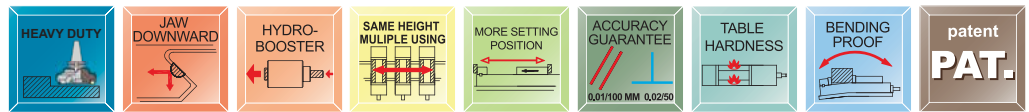
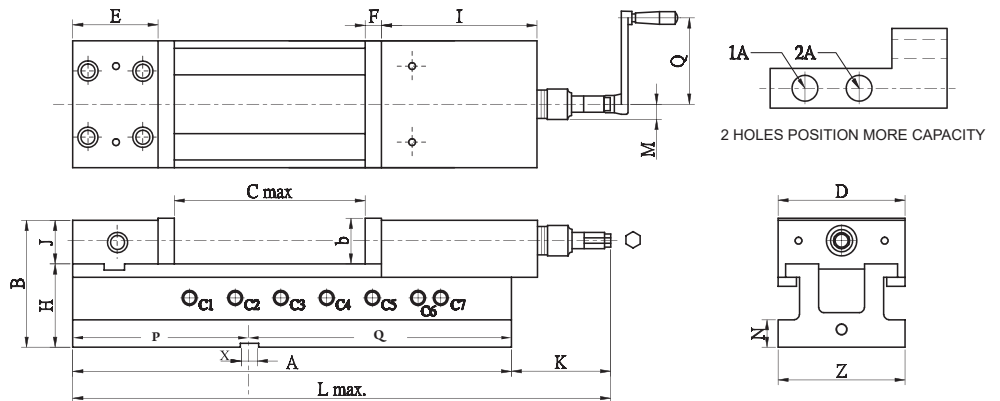

ORDER NO.	C MAX. Open	MAX. Clamping Force KN	L MAX. mm	Opening Size For Capacity							
				-	C1	C2	C3	C4	C5	C6	C7
VNC-100H	205	25	464	1A	2-30	57-90	115-146	173-205	-	-	-
				2A	0-3	28-60	86-116	145-175	-	-	-
VNC-125H	225	40	556	1A	10-46	70-106	130-166	190-226	-	-	-
				2A	0-12	38-72	98-132	158-192	-	-	-
VNC-160H	310	50	684	1A	13-70	93-150	173-230	253-310	-	-	-
				2A	0-30	53-110	133-190	213-270	-	-	-
VNC-160LH	509	50	884	1A	13-70	93-150	173-230	253-310	333-390	410-470	450-510
				2A	0-30	53-110	133-190	213-270	293-350	370-430	410-470

ORDER NO.	A	B	D	E	F	b	H	J	N	I	Z	X	P	Q	Weight (kgs)	CODE NO.
VNC-100H	380	107	100	67	13	38	70	37	24	133	100	14	152	228	23	4005-100
VNC-125H	432	126	124	85	15	45	82	44	27	147	125	18	174	258	37	4005-101
VNC-160H	550	148	159	102	18	54	95	53	27	189	160	18	219	331	63	4005-102
VNC-160LH	750	148	159	102	18	54	95	53	27	189	160	18	219	531	77	4005-103