



Precision Compact MC Vise

SAME HEIGHT GUARANTEE

for machining center



Mechanical Type
Great Smooth Operation



DESIGN FOR THIN WORKPIECE



MC POWER VISE

Features

- FCD 60 high quality ductile cast iron - body material - reduce the cutting vibration.
- Angle-fixed design : for vertical & horizontal cutting & processing machine.
- Everlasting clamping power.
- Heavy cutting.
- Hardness > HRC 45° : vise sliding bed.
- High durebility & high precision.
- Tolerance : 0.01/100mm
- Lift proof : press down design.
- Bending resistance : rigid & strong.
- Dust proof : concealed spindle.
- Fast & easy operation.

EXP.

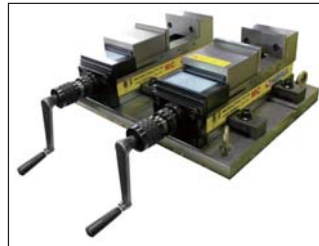

EXP.

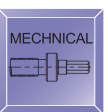
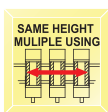
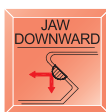
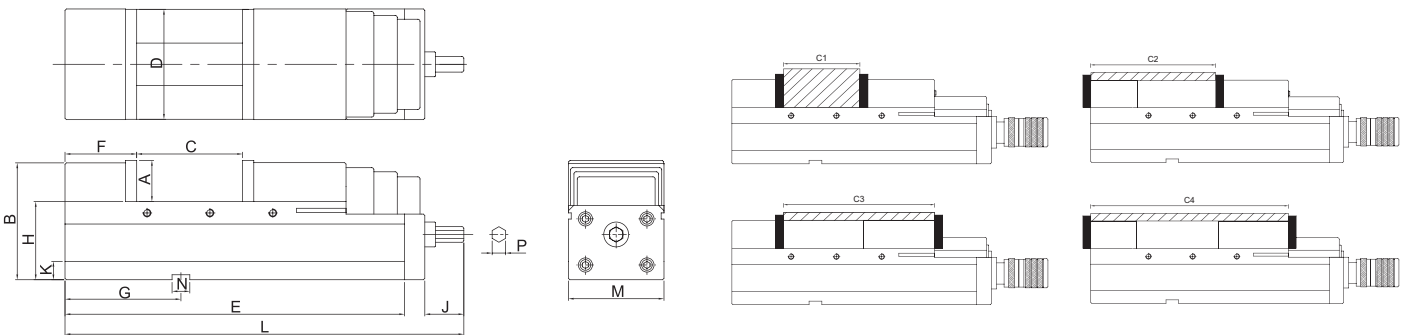
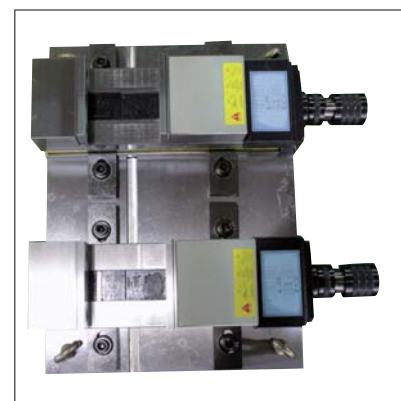

Mechanical Type

ORDER NO.	A	B	C OPEN	D	E	F	G	H	J	K	L	M	N	P	Clamping Force (kgf)	Weight Body	CODE NO.
VMC-100M	48	130	125	100	340	80	125	85	55	15	425	101	16	19	3000	26 kgs	4005-064
VMC-130M	55	147	180	130	405	85	150	96	55	21	490	131	18	19	3000	39 kgs	4005-065
VMC-160M	58	168	240	160	495	100	165	105	55	21	580	161	18	19	3000	60 kgs	4005-066
VMC-200M	61	170	280	200	570	118	190	110	55	21	655	201	18	19	3000	86 kgs	4005-067
VMC-160ML	58	168	340	160	595	100	165	105	55	21	680	161	18	19	3000	67 kgs	4005-058