

VCT-407

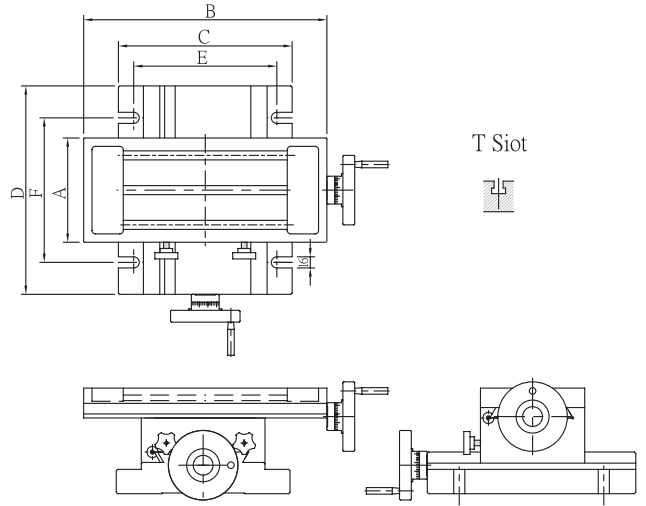

VCT-514



DRAWING OF VCT-514

Unit:mm

- Material: over FC-30
- Precision: 0.02/100mm

Specifications

ORDER NO.	A	B	C	D	E	F	Travel Stroke	T Slot	Total height	Dial graduation	PACKING LxWxH mm	WEIGHT kgs	MAX.LOAD kgs	CODE NO.
VCT-407	100	180	130	100	115	50	50x80	3/8"	100	2.5mm/0.02	290x240x140	12	35	1007-001
VCT-514	150	350	250	300	206	208	156x170	3/8"	134	4mm/0.02	510x450x240	33.5	105	1007-002
VCT-820	200	500	300	400	250	290	200x250	3/8"	155	4mm/0.02	640x520x200	72	140	1007-003
VCT-1024	250	600	400	500	340	430	250x300	1/2"	210	4mm/0.02	790x680x310	141	175	1007-004

Precision Cross Table

ORDER NO.VCT-830 CODE NO.1007-010



VCT-830

A heavy, rugged slide in all kinds of positioning, milling, drilling micro-scope viewing and staging, adjustable bases for heavy loads, small jig boring, precision cut-off.

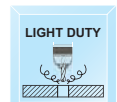
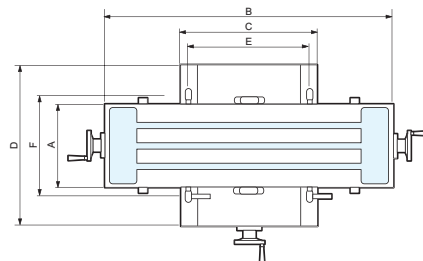

Unit:mm

Specifications

ORDER NO.	A	B	C	D	E	F	Travel Stroke	T Slot	Total height	Dial graduation	PACKING LxWxH mm	WEIGHT kgs	MAX.LOAD kgs	CODE NO.
VCT-830	210	730	345	405	305	230	190x350	16	185	2.5mm/0.05	991x584x292	100	35	1007-010