



2-Way Angle Milling Vise

TW PAT.



MECHANICAL TYPE

NEW

SUPER OPEN CAPACITY:
VWT-4B JAW OPENED 220mm
VWT-6B JAW OPENED 350mm



VWT-4B

VWT-6B

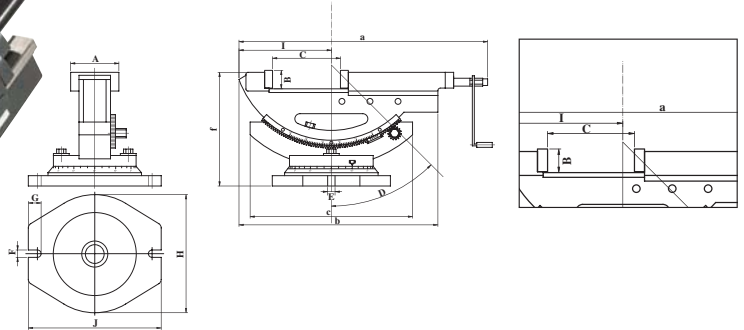

- Tilting seat set by two locking screws, works in high stability.
- Angle setting ranges from 0°~50°. Tilting degrees graduated for easy reading. Swivel base graduated to 360° and fixable in any position.

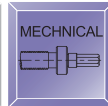
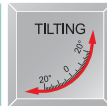

Order No. & Dimensions

ORDER NO.	A	B	C OPEN	D	E	F	G	H	I	J	a	b	c	f	Max. Clamp Force (kgf)	G.W. (kgs)	Meas CFT	CODE NO.
VWT-4B	110	36	220	50°	15	15	26	240	185	270	500	404	335	230	1200	(C) 33.3	1.2	1002-060B
VWT-6B	152	54	350	50°	20	19	28	300	246	330	800	585	415	290	1600	(W) 79.7	4.4	1002-061B



2-Way Machine Vise

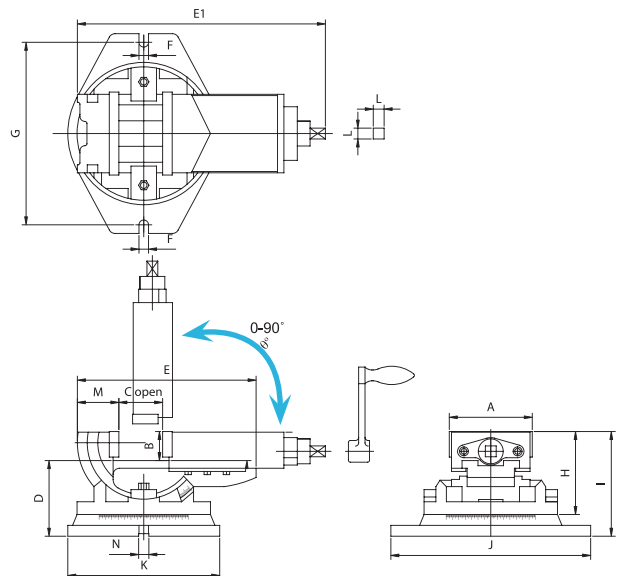

- Heavy cast iron structure
- Scales in both axis
- 360°swivel around Z-axis
- 90° vertical and horizontal swivel

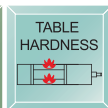
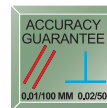

Order No. & Dimensions

ORDER NO.	A	B	C OPEN	D	E	E1	F	G	H	I	J	K	L	M	N	θ	Clamp Force(kgf)	Meas CFT	CODE NO.
VWT-5	130	46	100	118	280	415	15	286	130	164	313	238	17	65	16	0°~90°	900	31.7	1002-090
VWT-6A	160	51	120	140	360	510	17	293	150	191	328	252	17	83	16	0°~90°	1600	47	1002-091