

**NEW**

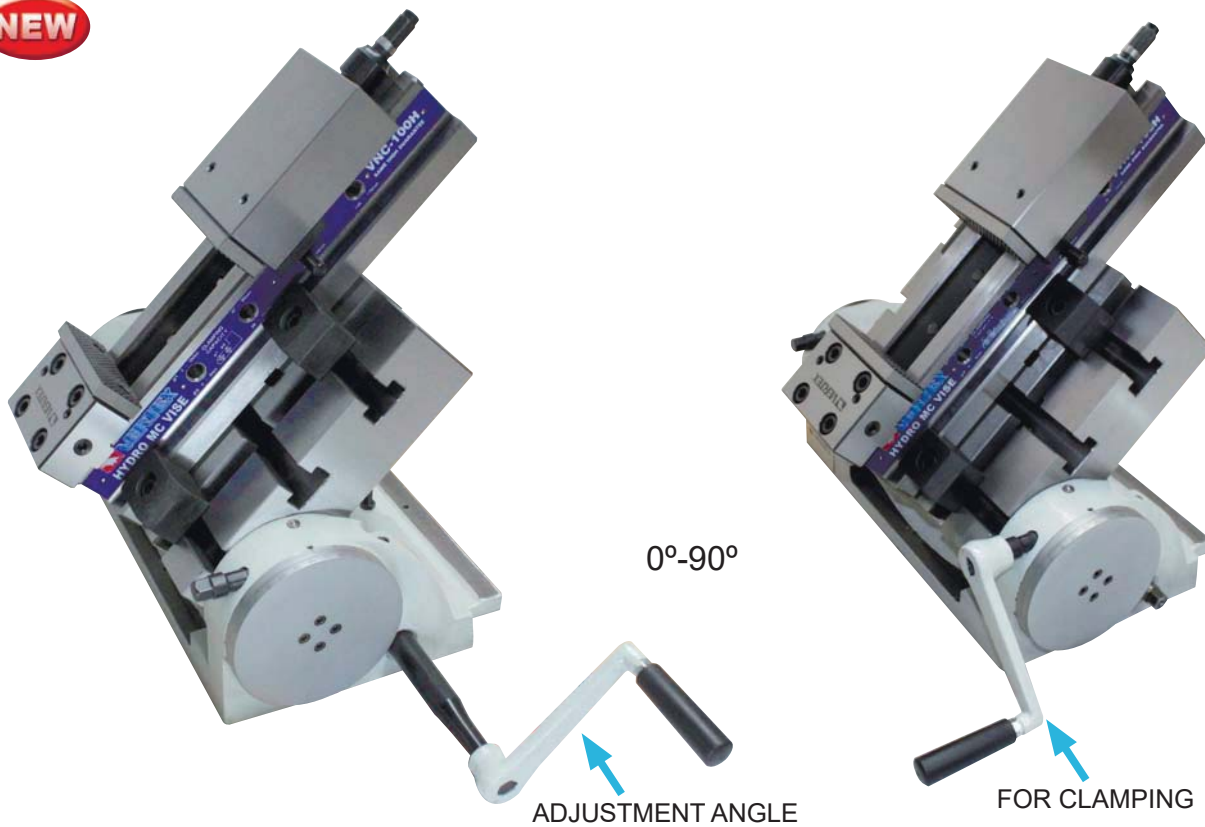

- Tilting by rigid & strong design, 2 supporter & rigid clamping system construction.
- Minimum set-up time.
- Tilting angle can adjusted by worm & worm gear system.
- Accurate and built for use in milling, boring and other machines.
- Worm shafts are hardened and ground.
- Tilting plate with slots enable Multi-position work fixing.
- Strong structure.
- Hydro-booster system for maximum clamping pressure with minimum force.
- Sliding bed ways flame hardened and ground.
- Compact design. Great clamping capacity. Light & smooth operation.
- Body is made of FCD60 ductile cast iron, High deflection/bending resistant.
- Constructed for machining center, milling, drilling, grinding and many other machine shop applications.

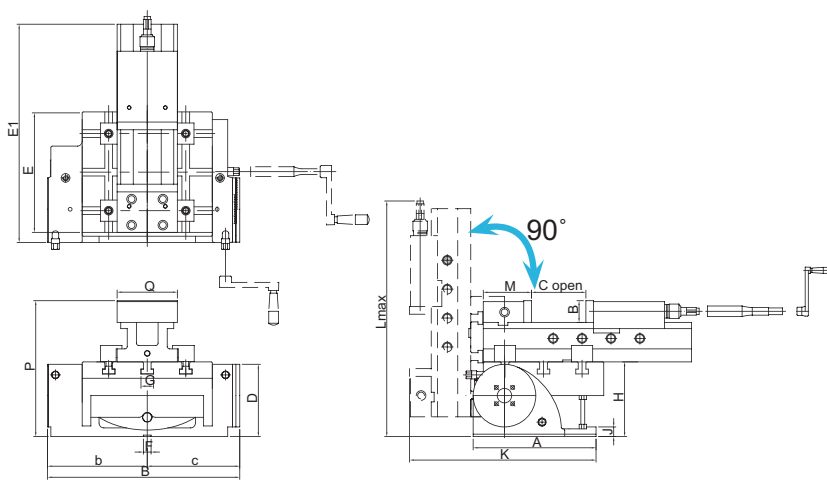

ORDER NO.	A	B	C open	D	E	E1	F	G	H	J	K	L max.	M	P	Q	b	c	CODE NO.
VUT-4NC	180	285	205	156	150	390	16	20	115	16	292	502	80	264	100	143	125	1002-251
VUT-5NC	255	399	225	270	258	442	16	22	155	20	386	619	100	397	124	210	187	1002-252
VUT-6NC	300	449	310	320	298	560	16	26	169	25	453	757	120	469	159	235	212	1002-253