



Economical Type Rapid Index



RAPID INDEX CHUCK



COLLET INDEXER NON ECONOMICAL

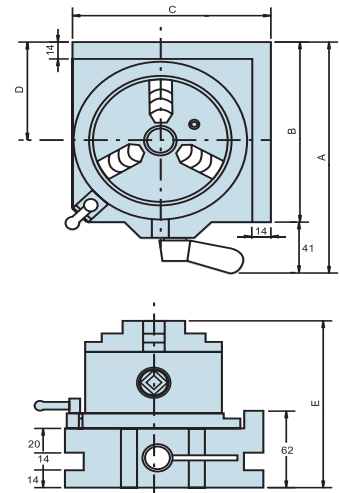

- 3 JAW CHUCK VSC-4A, for VSI-4 / VSC-5A for VSI-5, the big range clamping capacity $\varnothing 3 - \varnothing 100$, it's better than collet fixing type.
- Simple & rapid operation.
- Dividual number 24-notch (15° each)
- Table scale 1° , for angular indexing.
- Table bore 30mm.
- Horizontal / vertical & 2 direction
- Suit for milling & drilling machine using.
- Optional: tailstock TS-1, Please see page A2

ORDER NO.	A	B	C	D	E	Through Hole	kgs	CODE NO.
VSI-4	187	146	146	80	135	$\varnothing 30$	10.5	1001-064
VSI-5	202	161	161	87	142	$\varnothing 30$	14.5	1001-065



Simple Rotary Chuck

NEW

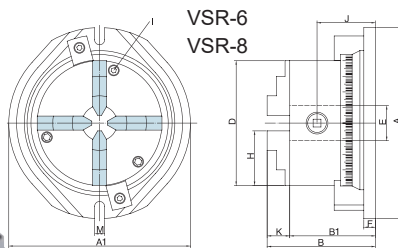

VSR-6 + VPS-6A 4JAW CHUCK
VSR-8 + VPS-8A 4JAW CHUCK

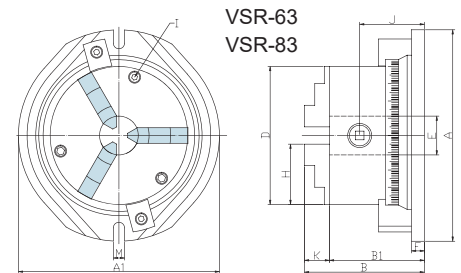

VSR-63 + VSC-6A 3JAW CHUCK
VSR-83 + VSC-8A 3JAW CHUCK

- 4-jaw chuck (include reversable and removable jaw) is designed with swivel base for multifunctional purpose.
- VERTEX simple rotary chuck can be placed and fixed on your desired position.
- 360° vernier scale: smooth swival motion and easy locking by screws.
- Both horizontal and vertical position could be used on milling and machining center.

ORDER NO.	FOR SHAPE	A	A1	B	B1	D	E	F	H	I	J	K	M	kgs	CODE NO.
VSR-6		245	233	139	110	160	45	15	70	3-M8	69	29	14	18	1001-068
VSR-8		305	270	159	125	200	65	20	86	3-M10	75	34	18	30.5	1001-067
VSR-63		245	233	139	110	160	45	15	70	3-M8	69	29	14	18	1001-068A
VSR-83		305	270	159	125	200	65	20	86	3-M10	75	34	18	30.5	1001-067A