



MC Power Vise Hydraulic Type



GERMAN TYPE
JAPAN TYPE

NEW

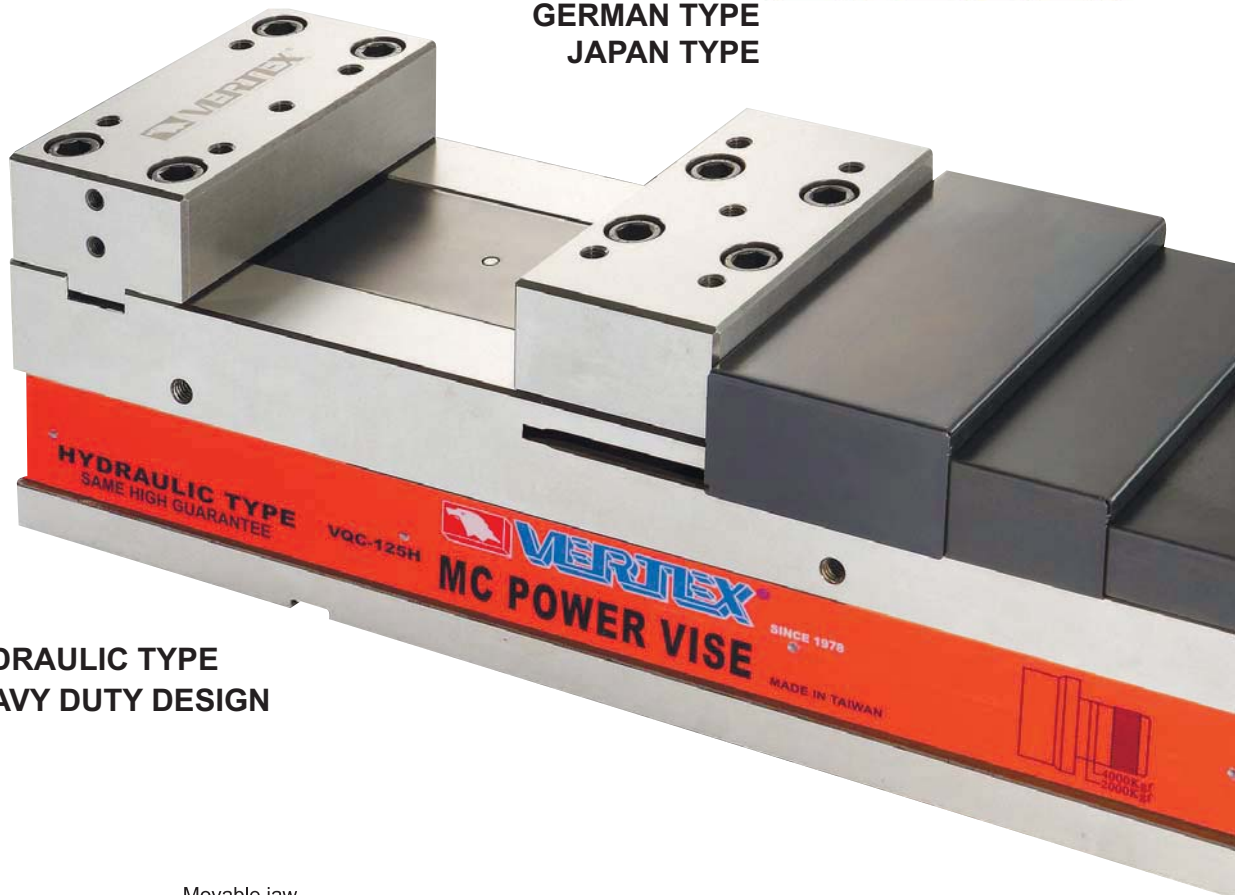

HYDRAULIC TYPE
HEAVY DUTY DESIGN

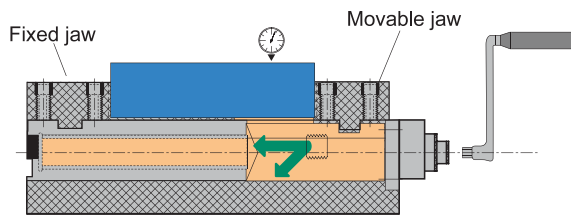

LOCK DOWN DESIGN

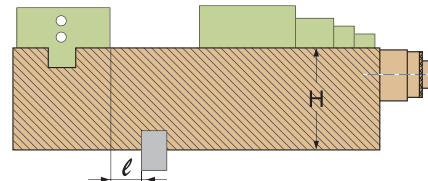

H-Accuracy $\pm 0.01\text{mm}$
l-Accuracy $\pm 0.01\text{mm}$

SAME HEIGHT GUARANTEE

Features

- Compact design. Great clamping capacity & rigid. Light & smooth operation.
- Constructed for milling, drilling, machining center, grinding and many other machine shop applications.
- Body is made of FCD60 ductile cast iron, HIGH deflection/bending resistant.
- Sliding bed ways flame hardened and ground.
- Concealed spindle for protection against chips and dirt.
- Hydro-booster system for maximum clamping pressure with minimum force.
- Quick of clamping & locking and easy of operation.
- Accuracy within 0.01/100mm.
- Hydro-booster system is guaranteed for using 2 years limited.
- The hydraulic oil number is 68#
- Hydro line - one scale indicate about 1/3 of the max. clamp force.

AA GRADE VISE

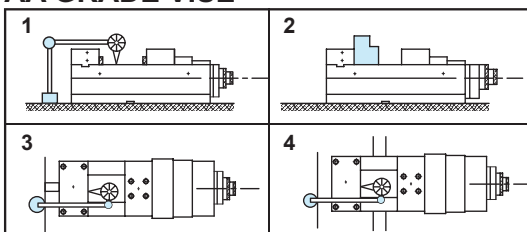

INSPECTION SPECIFICATION

NO.	Inspection Item	Per (100mm)	Guaranteed
1	Parallelism: table face to bottom of bed.		0.01/100mm
2	Squareness :between table face and jaw plate.		0.02/100mm
3	Squareness: keways on bottom of table face to jaw plate.		0.02/100mm
4	Parallelism: table face of the table face block to bottom of bed.		0.02/100mm



MC Power Vise Hydraulic Type



PATENT

SAME HEIGHT GUARANTEE

MC POWER VISE

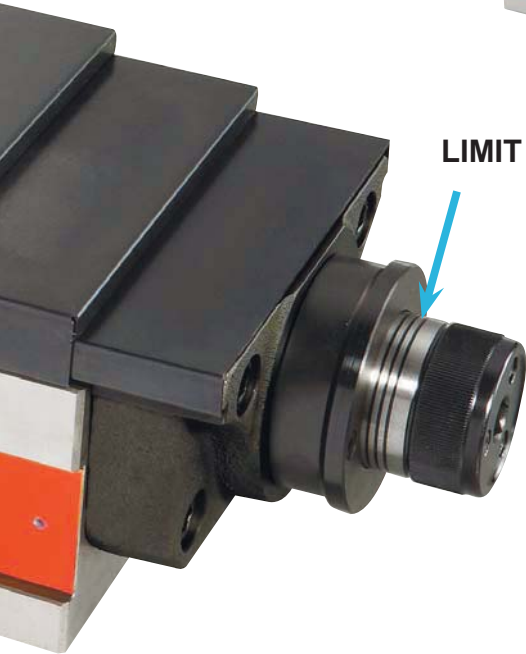

LIMIT HYDRO LINE

COMPACT DESIGN-
SMALL LENGTH BODY BUT
SUPER OPEN CAPACITY

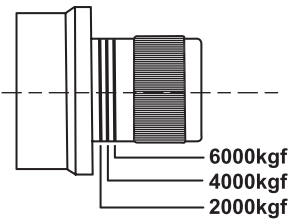

CLAMPING FORCE SCALE

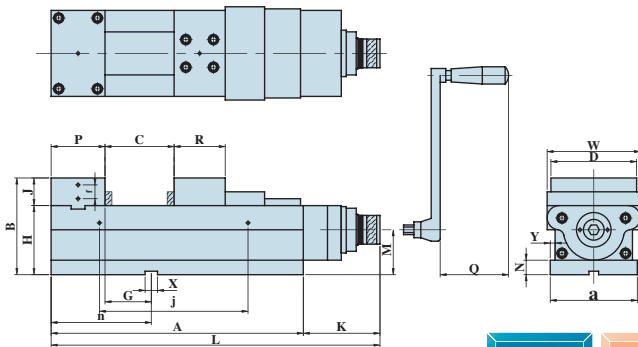
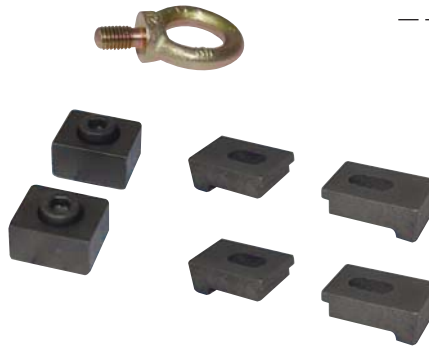

ORDER NO.	JAW J	JAW Open C	B	MAX. Clamping Force (KN)	G.W. kg
VQC-100H	35	128	120	30	26.2
VQC-125H	40	205	140	40	42.5
VQC-160H	45	275	165	60	66
VQC-160LH	45	355	165	60	78.79
VQC-200LH	70	405	190	60	108

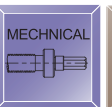
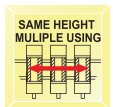

ORDER NO.	A	B	a	D	P	R	G	H	J	K	L
VQC-100H	273	120	105	99	73	64	39	85	35	110	383
VQC-125H	365	140	126	124.5	78	74	66	100	40	113.5	478.5
VQC-160H	455	165	161	159.5	86	86	58	120	45	125.5	580.5
VQC-160LH	535	165	162	160	86	86	58	120	45	125.5	660.5
VQC-200LH	615	180	202	200	102	98	74	120	70	122	737

ORDER NO.	M	N	Q	W	X	Y	C OPEN	f	j	n	CODE NO.
VQC-100H	50	15	74	110	14	6.5	128	20	105	112	4005-004H
VQC-125H	65	21	73	135	18	7	205	20	215	145	4005-005H
VQC-160H	78	21	93	170	18	7	275	20	285	145	4005-006H
VQC-160LH	78	21	93	174	18	7	355	20	285	145	4005-007H
VQC-200LH	75	21	95	217	18	7	405	20	385	177	4005-007AH