



# Modular Precision Machine Vise



SAME HEIGHT GUARANTEE

MACHINE VISE

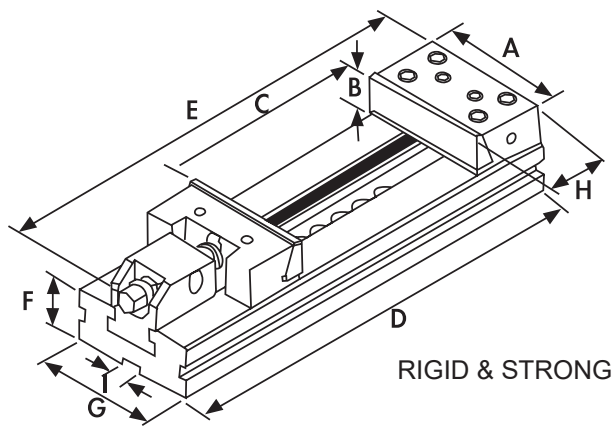
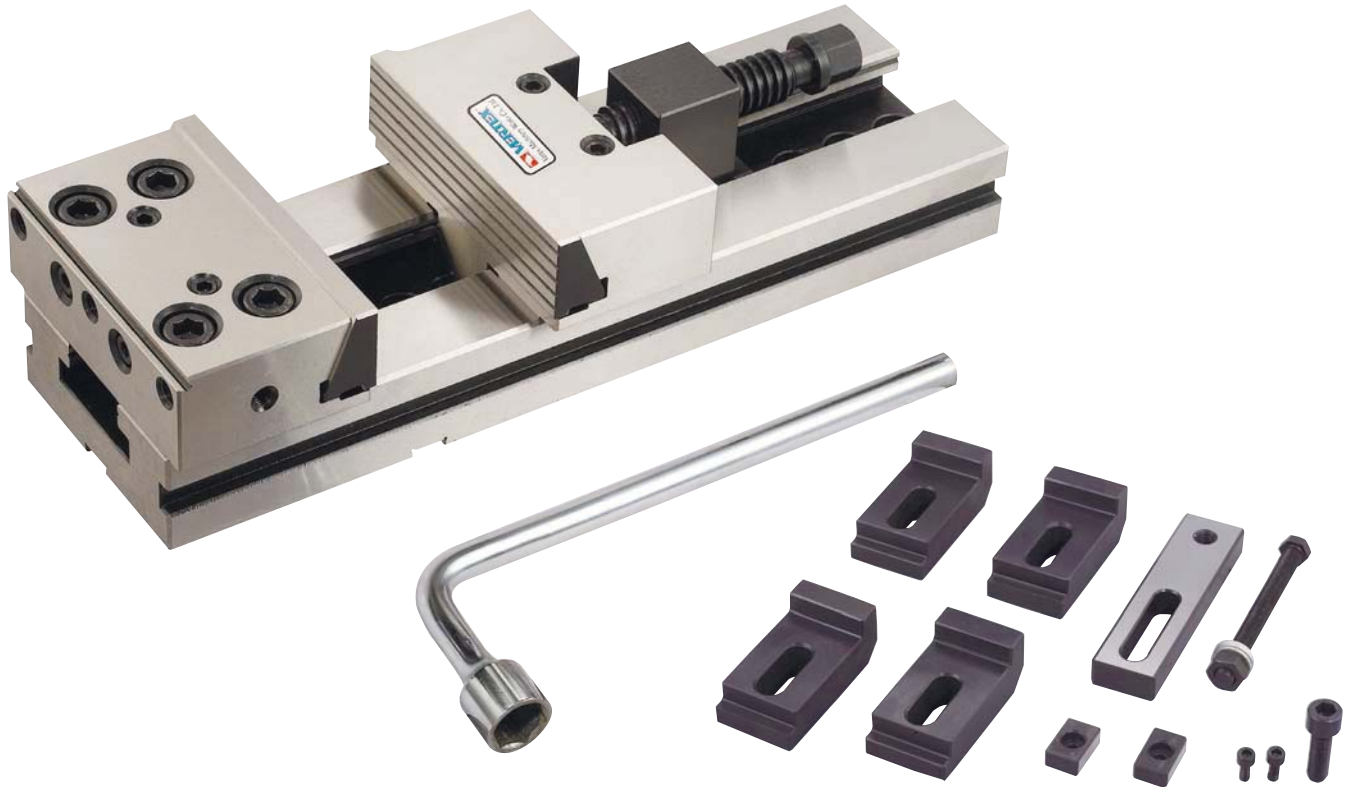

RIGID & STRONG

### Features

- High Accuracy 0.01/100 mm
- Unlimited Clamping Range
- High Quality Alloy Steel with HRC 59
- High Clamping Pressure
- EACH ONE IS SAME AS HEIGHT.
- CAN BE USED IN MULTIPLE STYLE.
- No Length of Height Limitation
- No Jaw Lift
- Low Profile
- All Vises are Matched parallelism  $\pm 0.01/100$  mm
- Optional : Swivel base

**SAME HEIGHT MULTIPLE USING**

**ACCURACY GUARANTEE**

0.01/100 MM 0.02/50

**TABLE HARDNESS**

**BENDING PROOF**

**MECHANICAL**

ORDER NO.	VMP -4	VMP -5	VMP -6	VMP -6B	VMP -6C	VMP -7A	VMP -7B	VMP -7C	VMP -8A	VMP -8B	VMP -8C	VMP -8D
<b>A</b>	100	125	150	150	150	175	175	175	200	200	200	200
<b>B</b>	30	40	50	50	50	60	60	60	65	65	65	65
<b>C OPEN</b>	100	150	200	300	400	200	300	400	200	300	400	500
<b>D</b>	270	345	420	520	620	455	555	655	573	595	695	795
<b>E</b>	325	360	530	600	700	620	620	620	718	718	718	880
<b>F</b>	35	40	50	50	50	58	58	58	70	70	70	70
<b>G</b>	75	96	125	125	125	145	145	145	170	170	170	170
<b>H</b>	78	78	90	89.4	89.4	97	97	97	114	114	114	113.4
<b>I</b>	16	16	16	16	16	16	16	16	16	16	16	16
<b>Max. Clamp Force (kgf)</b>	900	1300	2000	2000	2000	2000	2000	2000	2000	2000	2000	2000
<b>KGS</b>	9.2	16	28.5	34.8	38.1	43.7	48.3	53.5	66.3	73.2	81.3	87.2
<b>CODE NO.</b>	1002-190	1002-191	1002-192	1002-201	1002-202	1002-193	1002-194	1002-195	1002-196	1002-197	1002-198	1002-203