



# Modular Precision Hydraulic Machine Vise



PAT.

SAME HEIGHT GUARANTEE

NEW

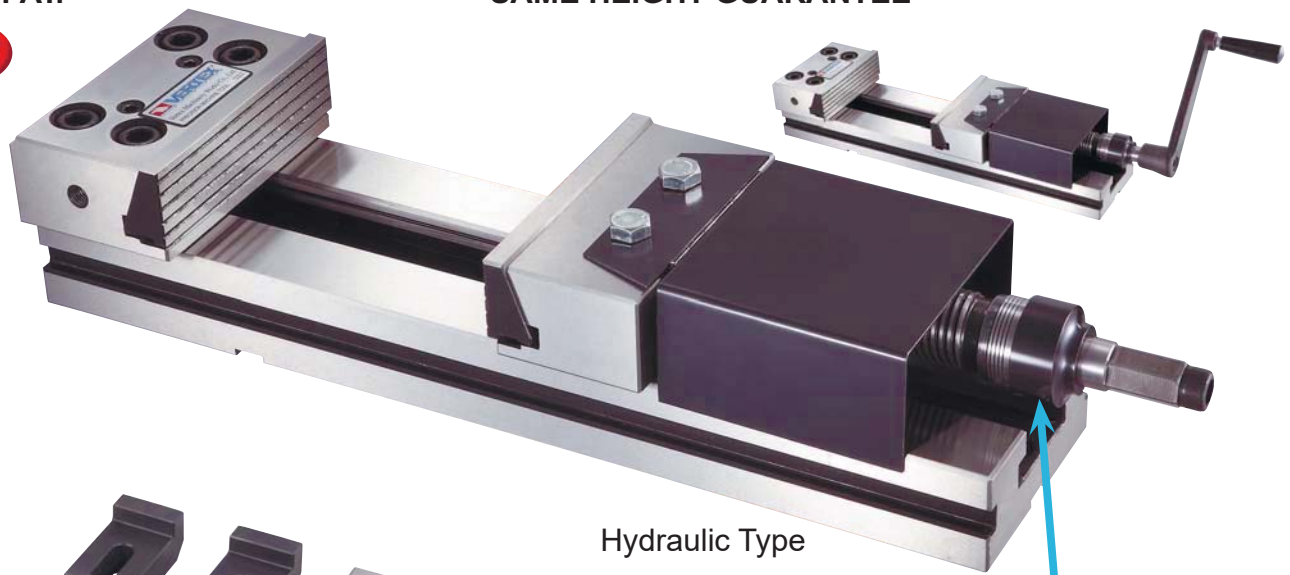

Hydraulic Type

Hydraulic Control Unit

### Features

- New design: Adjustable pressure device.
- Suit for processing of brass, AL, plastic, steel.
- New design: super open jaw size, smallest open jaw size. lock proof system: prevent wrong clamping force sticks the vise.
- Hydraulic clamping force 4500kg for heavy duty cutting. The screw mechanism type clamping force is 2200 kgs
- Smooth & light operation for the handle.
- High accuracy 0.01/100 mm
- Unlimited clamping range
- High quality alloy steel with HRC 59
- High clamping pressure
- Each one is same as height.
- Can be used in multiple style.
- No length of height limitation
- No jaw lift
- Low profile, strong & rigid.
- All vises are matched parallelism  $\pm 0.01/100$  mm

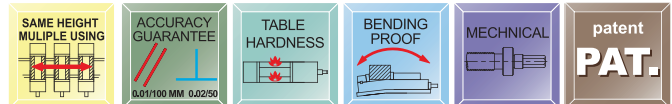
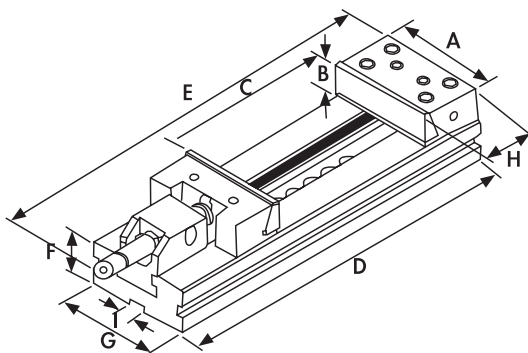

ORDER NO.	VMP -6BH	VMP -6CH	VMP -7AH	VMP -7BH	VMP -7CH	VMP -8AH	VMP -8BH	VMP -8CH	VMP -8DH
A	150	150	175	175	175	200	200	200	200
B	50	50	60	60	60	65	65	65	65
C OPEN	300	400	200	300	400	200	300	400	500
D	520	620	455	555	655	573	595	695	795
E	660	760	680	680	680	778	778	778	940
F	50	50	58	58	58	70	70	70	70
G	125	125	145	145	145	170	170	170	170
H	89.4	89.4	97	97	97	114	114	114	113.4
I	16	16	16	16	16	16	16	16	16
Max. Clamp Force (kgf)	4500	4500	4500	4500	4500	4500	4500	4500	4500
KGS	29	33	38	43	48	65	69	74	90
CODE NO.	1002-201H	1002-202H	1002-193H	1002-194H	1002-195H	1002-196H	1002-197H	1002-198H	1002-203H