



Tilting Hydraulic Machine Vise



PATENT

New Design

- Jam proof system
- Great smooth operation
- Hydro limit proof.
- Screw shaft broken proof

VHT-4



VHT-6



TILTING ADJUSTABLE BY GEAR SYSTEM

50°

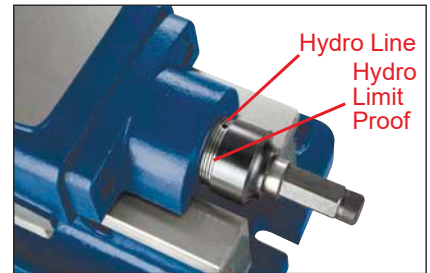
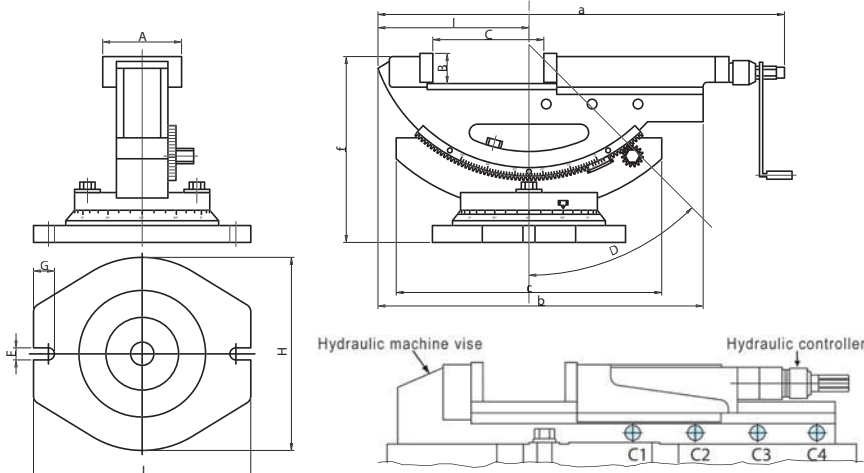

Hydraulic controller: provide stable pressure, hydro indexer. Protect the hydro system.

- The same as characters of VH type. Swivel base same as VH type.
- Tilting seat set by two locking screws, works in high stability.
- Angle setting ranges from 0°~50°. Tilting degrees graduated for easy reading.
- Swivel base graduated to 360° and fixable in any position.
- THE (3 STEPS CLAMPING POSITION) SAME AS VH TYPE.
- Accuracy within 0.02mm
- Hydraulic-booster system is guaranteed for using 1 years limited.

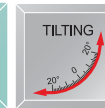
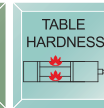

ORDER NO.	A	B	C OPEN	D	E	F	G	H	J	a	b	c	f	Max. Clamp Force (kgf)	G.W. (kgs)	Meas CFT	CODE NO.
VHT-4	110	36	170	50°	15	15	26	240	270	500	404	335	230	2500	(W)33.3	1.2	1002-020
VHT-6	154	54	300	50°	20	19	28	300	330	800	585	415	290	4500	(W)88	4.4	1002-021

CLAMPING CAPACITY (3 STEPS CLAMPING POSITION FIG)

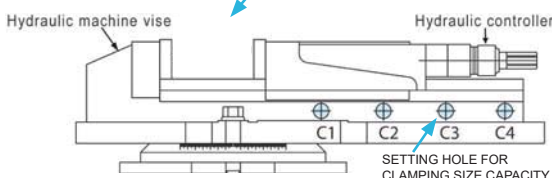

Swivel base

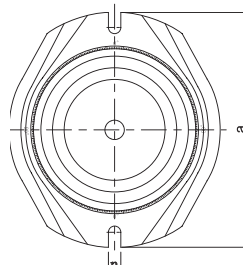

Swivel base

Unit:mm

ORDER NO.	a	b	c	n	Q	G.W. (kg)	CODE NO.
HS-4	280	210	30	16	15	4	1002-010
HS-5	297	267	43	16	20	7	1002-011
HS-6	335	310	40	16	20	10	1002-012
HS-8	373	355	45	16	22	16	1002-013