

# Free Angle Vise



**NEW**



## Features ANY TILTING ANGLE

- Special design for quick clamping. (From the acme thread shaft stationly)
- Quick setting by sliding movement. Big clamping capability.
- Operating very quick and easy, can increase so much working efficiency than you can image.
- 360° Rotation, Tilting 30°
- Most free angle vise
- For non-normal angle setting.
- Its swivelling and tilting features with clamping make this unit for straight or inclined surface, angular drilling machining on various machine tools or for bench work table.

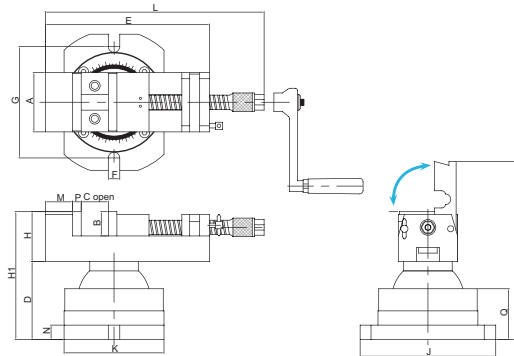

**LIGHT DUTY**

**TILTING**

**ACCURACY GUARANTEE**  
0.01/100 MM 0.02/50

**MECHANICAL**

**patent PAT.**

ORDER NO.	A	B	C OPEN	D	E	F	G	H	H1	J	K	L	M	N	P	Q	R	MAX. Clamp Force (kgf)	Weight (kgs)	CODE NO.
VAV-3	82	34	85	110	230	17	158	70	194	190	140	374	38	20	12	72	268	700	17.6	1002-214
VAV-4	106	36	104	120	256	17	158	72	206	190	140	422	38	20	16	72	280	800	21.4	1002-215

# Lock-Fixed II Precision Machine Vise

ORDER NO. VMC-4  
VMC-6



Performed sided vertically.

- With the ability of lock-fixed III 2, 3, 4, 5.
- Use the semi-sphere segment principle.
- When operate several vises (in a row) put on one machine bed, the operating situation is as shown.

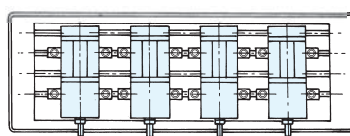
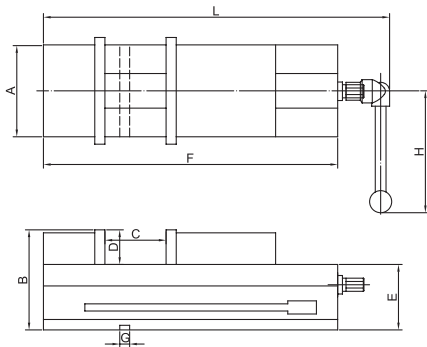

Aligned Performance

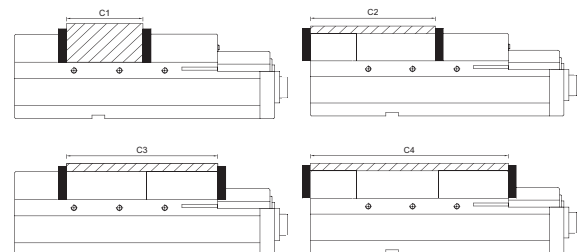

**LIGHT DUTY**

**JAW DOWNWARD**

**SAME HEIGHT MULTIPLE USING**

**MORE SETTING POSITION**

**ACCURACY GUARANTEE**  
0.01/100 MM 0.02/50

**TABLE HARDNESS**

**BENDING PROOF**

**MECHANICAL**

ORDER NO.	A	B	C OPEN	D	E	F	G	L	H	Max. Clamp Force (kgf)	Meas CUFT	Weight (kgs)	CODE NO.
VMC-4	108	100	103	36	63	283	16	374	202	1500	0.4	14.2	1002-185
VMC-6	156	120	142	46	74	370	16	472	221	2500	1.1	29.8	1002-186