

Angle Plate



VAP-1



VAP-2



VAP-3

90° V-way. High carbon steel hardened to 50°-54° HRC, precision ground to within 0.005mm accuracy in squareness. Angle tolerance ± 10 minutes. Sets any angle 0-60°, vernier reading 10 minutes. 2 set screws provided for firmlocking at fixed angle.
 Material: SK2
 Hardness: HRC 50°-54°
 Squareness: ± 0.01 mm
 Angular measures from 0°-60°
 ※ Not for LAB

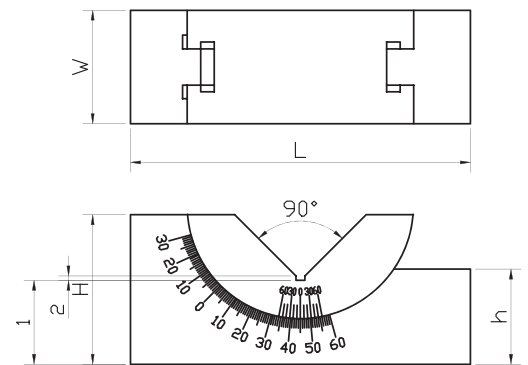
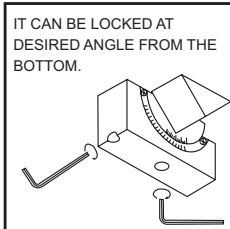
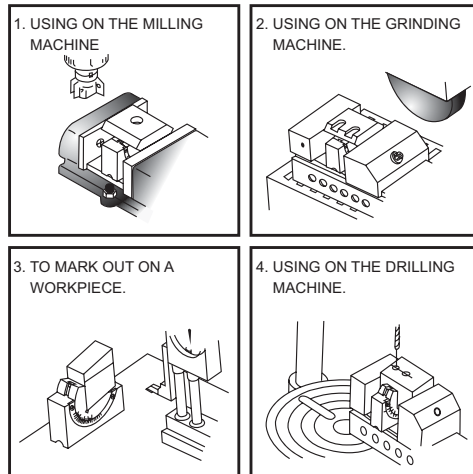

Unit:mm

ORDER NO.	H	W	L	h	N.W. (KGS)	CODE NO.
VAP-1	48	45	102	28	1.4	2005-001
VAP-2	49	30	102	28	0.9	2005-002
VAP-3	32.5	25	75	21	0.5	2005-003

Micro-Adjustable Angle Plate

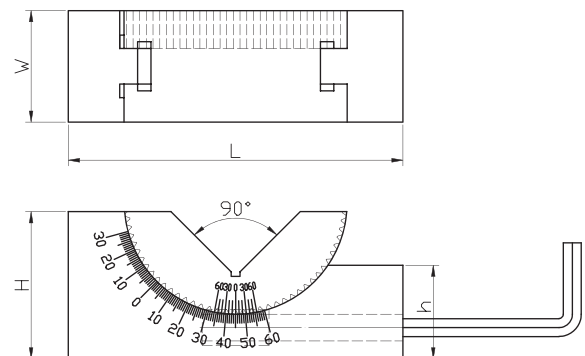

Angle Can Be Adjusted From 0°-60° By Screw
 ※ Not for LAB

Unit:mm

ORDER NO.	H	W	L	h	N.W. (KGS)	CODE NO.
VAPM-1	47	46	102	28	1.4	2005-010
VAPM-2	47	30	102	28	1	2005-011
VAPM-3	32	25	75	22	0.5	2005-012