

NEW

VD-690
VD-810

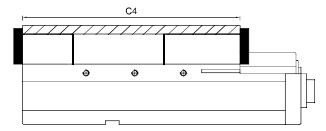

- The enclosed lead screw and sliding surface are harden and ground.
- Highest clamping power. It's very accurate and durable.
- This Vise is so designed that the horizontal Force generated by tightening the handle pushes the semisphere within the movable jaw and thus thrusts the movable jaw downward - angle lock feature.
- There fore, the workpiece does not lift, even if it is held at the top of the jaw plates.
- Four setting positions of the jaw plates are available, widening the jaw plates opening.
- ACCURACY WITHIN 0.02mm
- Mini order quantity : 3 sets for same height by request.
- In order to ensure the accurence when using it' better that don't put swivel base together

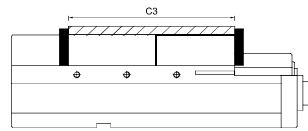
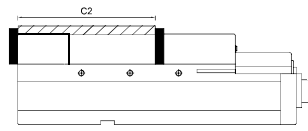
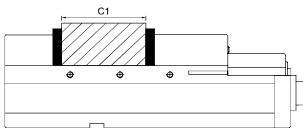
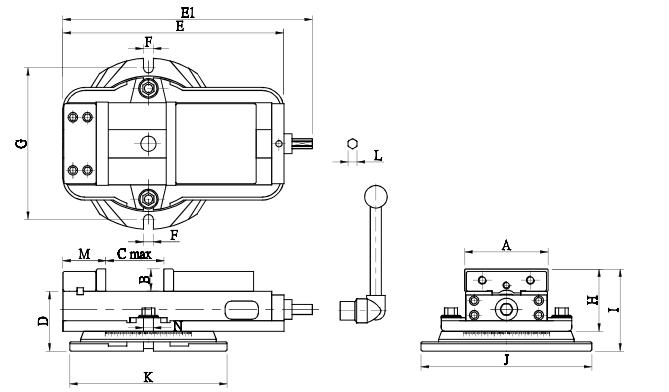
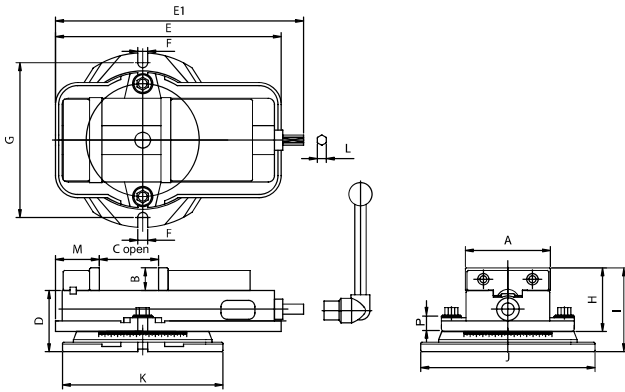
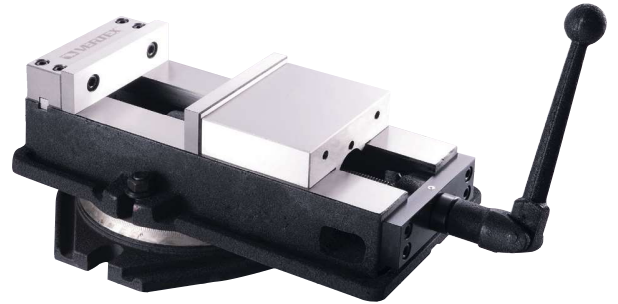
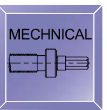
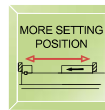

Order No. & Dimensions

ORDER NO.	A	B	C OPEN	D	E	E1	F	G	H	I	J	K	L	M	N	P	MAX. Clamp Force (kgf)	G.W. (KG)	C.F.T. (CM)	CODE NO.
VA-4	106	36	103	90	324	351	13	211	96	126	242	228	14.5	75	16	15	1500	20	35x24x15	1002-030
VA-5	135	36	110	97	359	394	17	246	101	133	277	255	14.5	85	16	15	2000	30	41x31x17	1002-031
VA-6	155	46	150	110	422	452	20	288	118	158	326	302	19	95	16	17	2500	42	49x35x20	1002-032
VA-8	210	60	197	129	553	583	19	355	145	190	395	366	19	105	16	19	3000	80	63x41x24	1002-033
VD-675	160	49	190	110	445	478	19	296	121	160	333	305	19	80	16	17	2500	42	52x35x21	1002-034
NEW VD-690	155	46	230	110	450	480	20	288	118	158	326	302	19	67	16	17	2300	43	49x35x20	1002-034B
NEW VD-810	205	62	275	129	555	615	19	378	147	191	420	377	19	79	16	17	3000	76	63x41x24	1002-035B