

Punch Former

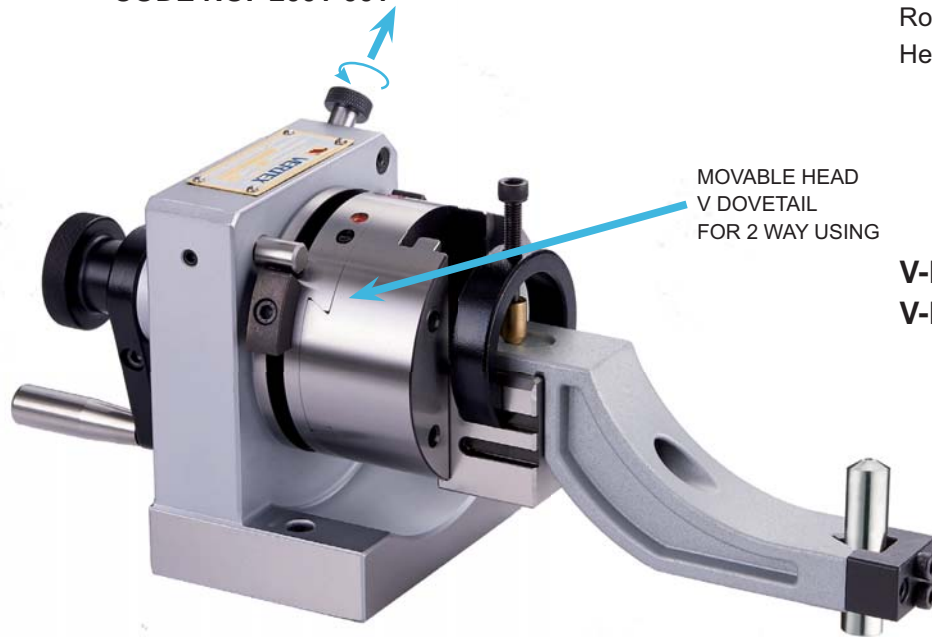

ORDER NO. V-PB
CODE NO. 2001-001

MAX. Wheel D. Ø200mm
Roller Center H. 80mm WEIGHT:10KGS
Head Slide Movement, 12.5mm



V-PB 2WAY
V-PS 1WAY, THROUGH HOLE

PULL & TURN TO 90° FOR SETTING

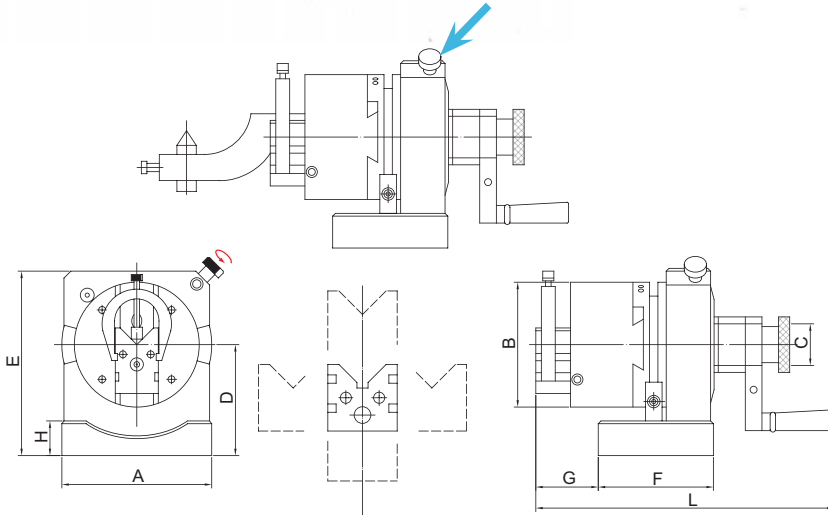

- Punch former is the fixture to grind the point of standard punches and E.D.M. electrodes for precise and fast operation.
- Besides the round, radius and multiangle punches, any special forms can be ground precisely .
By V-PB, punch/ grinding wheel can be ground either concave or convex radius shape.
- The capacity is from 4mm to 30mm.
- Punch Former is a great dressing instrument. Precisely forming the grinding wheel can be done by assembling an ARM with the main body. Any combination of tangents or radial form of the grinding wheel may be dressed accurately by easy operation.
- Max. diameter of grinding wheel within 200mm can be dressed accurately and safely. The height from base to roller's center is 80mm. Movement of each side can reach 12.5mm while aiming at the center of V block.
- The main body is made of one piece steel construction.

ORDER NO.	A	B	C	D	E	F	G	H	L	WEIGHT (kgs)	CODE NO.
V-PB	108	Ø90	Ø30	80-81	133	83	45	25	215	10	2001-001

Application grinding wheel style:

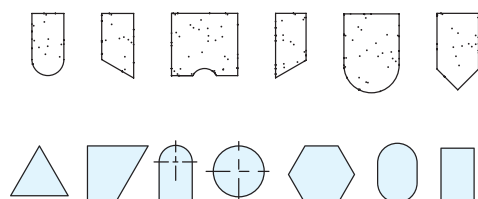

Surface Grinder

