



# Universal Dividing Head



BS-2



## Standard Accessories



DIVIDING HEAD

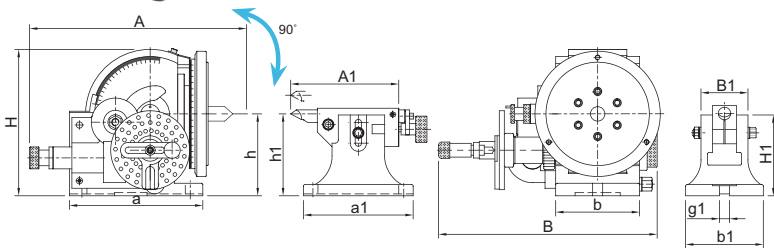

BS-2-J-8  
THE CHUCK FIXING  
HOLE IS FROM FRONT.



BS-2T TYPE

Thread Spindle: 2 1/4" - 8tpi  
Call To Check Old Model's Stock.

## BS-2, 2A (Head-stock)

Unit:mm

ORDER NO.	A	B	H	I	a	b	g	h	Taper of center	SPINDLE THROUGH HOLE	CODE NO.
BS-2	359	340	235	20	212	135	16	134	MT-4	25	1001-052
BS-2A	285	202	237	20	213	134	16	134	MT-4	25	1001-057

ORDER NO.	WITH CHUCK	WEIGHT (kgs)	CODE NO.
BS-2		65	1001-052
BS-2-J-6	6"	78.5	1001-055
BS-2-J-8	8"	80	1001-056
BS-2A		47.5	1001-057
BS-2A-J-6	6"	57	1001-058
BS-2A-J-8	8"	63	1001-059

## BS-2, 2A (Tail-stock)

Unit:mm

ORDER NO.	A1	B1	H1	I1	a1	b1	h1	g1	N.W. (KG)
BS-2	135-175	75	130	15	175	125	120-145	16	10
BS-2A	218	74	139	15	175	124	134	16	10

ORDER NO.	Gross Weight kg	Meas. CFT	Applicable Chuck
BS-2	(C)65	3.4	6" OR 8" F TYPE
BS-2A	(C)47.5	1.24	6" OR 8" F TYPE



# Semi-Universal Dividing Head BS-2A

NEW

BS-2A

Semi-UNIVERSAL DIVIDING HEAD W/O CHANGE GEAR TYPE

## Standard Accessories

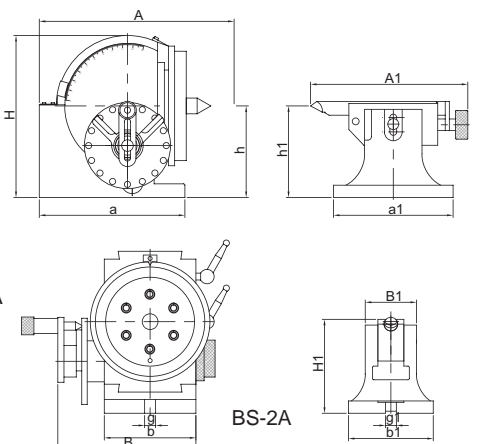

BS-2A COMES WITH A TAIL STOCK, A SET OF DIVIDING PLATE, A SET OF CARRIER CLAMP, A 3 JAW PLATE, A CENTER  
BS-2A BODY STRUCTURE IS SAME AS BS-2 WITHOUT CHANGING GEAR ARBOR OR BRACKET. OTHER ACCESSORIES ARE SAME AS BS-2.

BS-2A