



M/C Angle Plate 90°



● COLOR MAY VARY



M12

M12 LOCATION HOLE

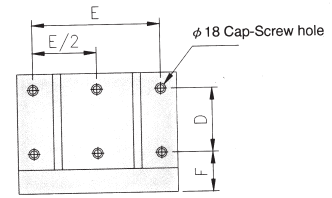
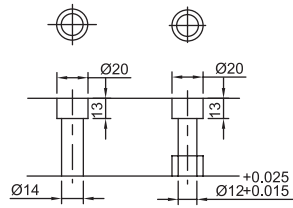

M16

M16 LOCATION HOLE

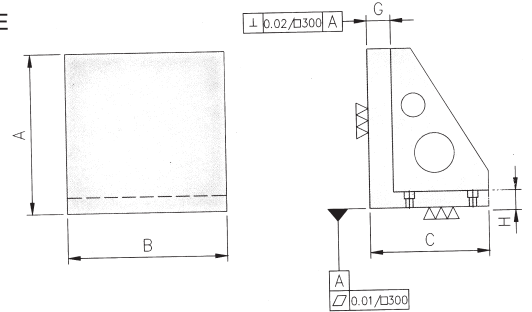
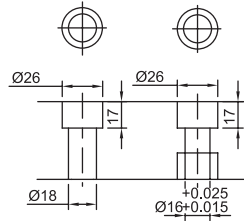

- Material/Finish:
Material:FC30(JIS)/GG30(DIN)
Heat treated (Normalized)
- Application: Good for horizontal M/C
- eye bolt included.

ORDER NO.	A	B	C	D	E	F	G	H	kgs	CODE NO.
BP20-30	300	300	220	100	250	90	40	30	52	4007-001
BP20-40	400	400	280	160	320	90	40	30	90	4007-002
BP20-50	500	500	350	200	400	90	50	35	175	4007-003
BP20-60	630	630	450	250	500	100	50	40	305	4007-004
BP20-80	800	800	550	302	640	115	50	45	480	4007-005



M/C Angle Plate 90°

T-SLOT TYPE

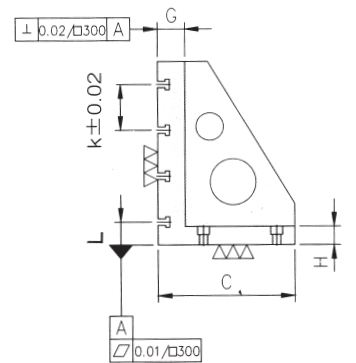
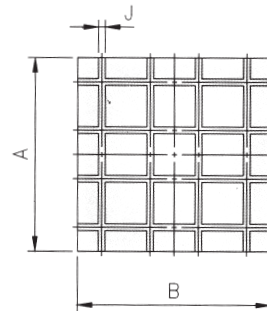
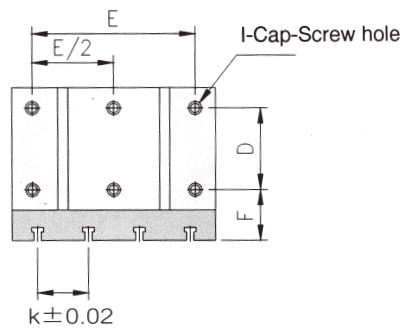

● COLOR MAY VARY

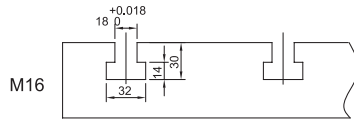
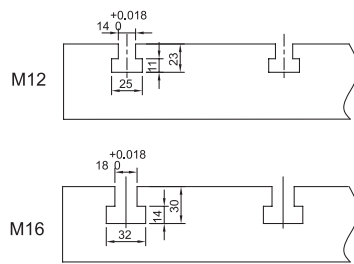

ORDER NO.	A	B	C	D	E	F	G	H	I	J	K (+0.02)	L	KGS	CODE NO.
BP22-30	300	300	220	100	250	90	60	30	Ø18	14	100	50	62.5	4007-010
BP22-40	400	400	280	160	320	90	60	30	Ø18	14	100	50	114.2	4007-011
BP22-50	500	500	350	200	400	90	60	35	Ø18	14	100	50	184	4007-012
BP22-60	630	630	450	250	500	100	60	40	Ø18	14	125	65	316	4007-013
BP22-80	800	800	550	320	640	115	75	45	Ø18	14	150	100	577	4007-014
BP22-830	300	300	220	100	250	90	60	30	Ø18	18	100	50	59.2	4007-015
BP22-840	400	400	300	160	320	90	60	30	Ø18	18	100	50	111.2	4007-016
BP22-850	500	500	350	200	400	90	60	35	Ø18	18	100	50	184	4007-017
BP22-860	630	630	450	250	500	100	65	40	Ø18	18	125	65	304	4007-018