

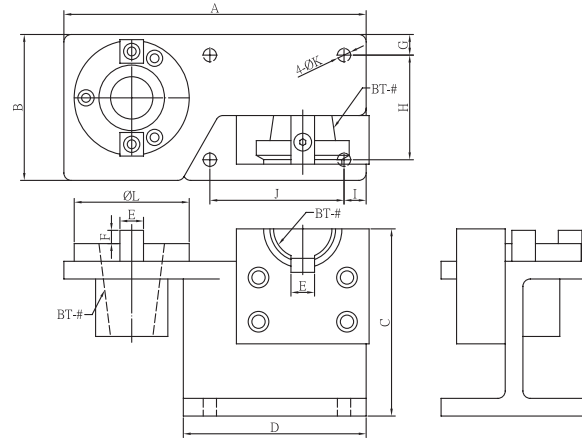

Tool Holder Locking Device



ORDER NO.	A	B	C	D	E	F	G	H	I	J	K	L	CODE NO.
VTG-BT30	205	99	127	124	15	10	16	71	15	91	9	78	3405-020
VTG-BT40	205	99	127	124	16	9	14	71	15	91	9	78	3405-021
VTG-BT50	282	152	203	162	25	16	22	108	25	115	9	115	3405-022

ORDER NO.	STD	WEIGHT (KGS)	CODE NO.
VTG-BT30	ISO BT	4.1	3405-020
VTG-BT40		4.2	3405-021
VTG-BT50		11.8	3405-022
VTG-SK30	CAT SK DIN69871A	3.7	3405-023
VTG-SK40		4	3405-024
VTG-SK50		12.3	3405-025