

# Hydraulic Machine Vise



PATENT

- New design: Adjustable pressure device.
- Jam proof system.
- Hydro limit proof.
- Screw shaft broken proof



VH-6



VH-12

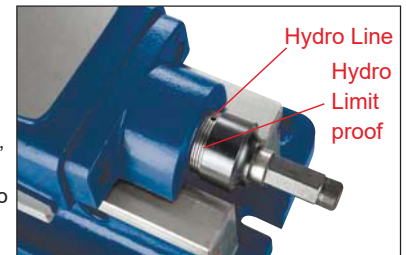

Hydraulic controller: provide stable pressure, Hydro indexer. Protect the hydro system. Hydro limit proof reference scale.

- New design: jam proof system: prevent wrong clamping force sticks the vise.
- Constructed for milling, drilling, shaping, grinding and many other machine shop applications.
- Sliding bed ways flame hardened and ground.
- Concealed spindle for protection against chips and dirt.
- Hydraulic-booster system for maximum clamping pressure with minimum force.
- Quick of clamping & locking and easy of operation.
- Accuracy within 0.02mm.
- Furnished with or without swivel base.
- Hydraulic-booster system is guaranteed for using 1 years limited.
- The hydraulic oil number is #68.
- Hydro line - one scale indicate about 1/3 of the max. clamp force.
- In order to ensure the accuracy when using it' better that don't put swivel base together

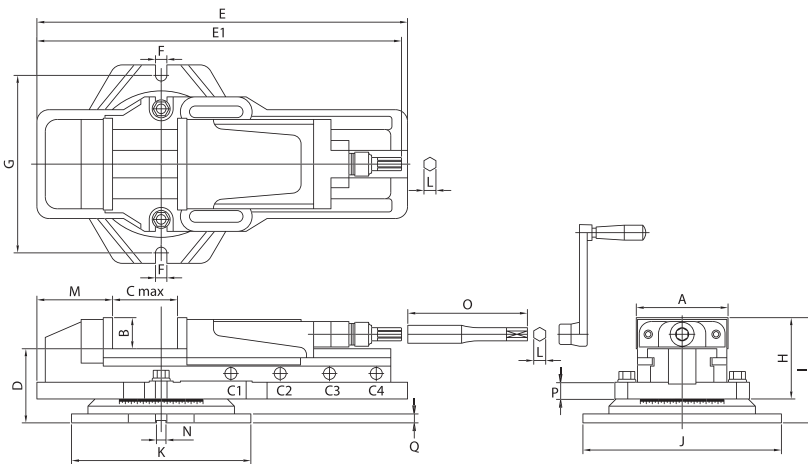

## Order No. & Dimensions



ORDER NO.	A	B	C max	Opening Size For Capacity				D	E	E1	F	G	H	I	J	K	L	M	N	O	P	Max. Clamp Force (kgf)	G.W. (kgs)	CFT (cm)	CODE NO.
				C1	C2	C3	C4																		
VH-4	108	36	175	0-63	61-120	118-175		98	443	583	14	235	95	135	270	240	14	110	16	156	22	2500	28	45x25x16	1002-001
VH-5	132	48	210	0-75	73-150	148-210		113	550	703	17	253	118	161	290	263	19	124	16	165	22	4500	47	56x28x18	1002-002
VH-6	151	52	300	0-100	98-200	198-300		124	620	800	19	298	136	176	332	300	19	126	16	200	30	4500	63	65x34x22	1002-003
<b>NEW</b> VH-6L	151	52	300	0-100	98-200	198-300	298-355	124	620	800	19	298	136	176	332	300	19	126	16	200	30	4500	63	65x34x22	1002-007
VH-8	204	62	300	0-100	98-200	198-300		144	680	857	17	342	162	206	375	350	19	155	16	200	30	7500	110	71x38x25	1002-004
<b>NEW</b> VH-8L	204	62	400	0-100	98-200	198-300	298-400	144	795	950	17	342	162	206	375	350	19	155	16	200	30	7500	108	84x42x30	1002-005
<b>NEW</b> VH-12	305	72	375	0-75	73-175	173-275	273-375	144	795	950	17	342	162	206	375	350	19	170	16	200	30	7500	138	84x35x27	1002-006