



New Model



HV-4

HV-6, 8, 10, 12, 14, 16

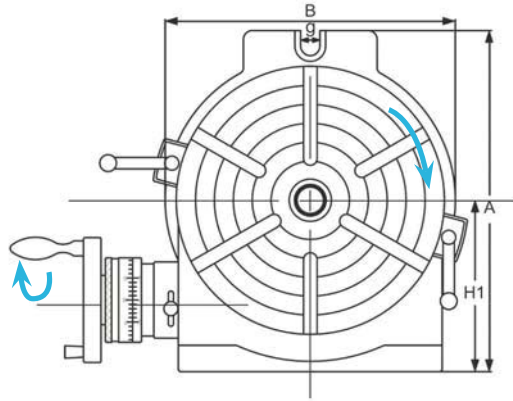
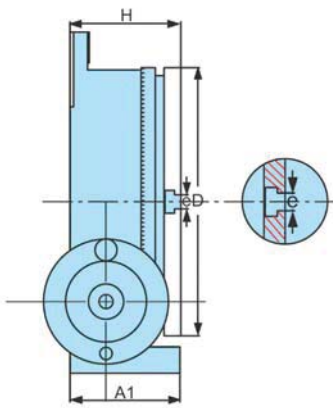

SPECIFICATIONS	HV-4,6	HV-8,10,12,14,16
Degree per one handle rotation	4°	4°
Scale of micro collar	2'	1'
vernier reading	20"	10"
Gear ratio	1:90	1:90

Specifications

ORDER NO.	Table		Base dimension			Width of T-slot		Bolt slots	The Load Capacity For Rotary Table		Center sleeve	Gross Weight(kg)		Meas. CFT	CODE NO.	
	Outer diameter	Height	H1	A	B	e	Type		g	Horizontal		Vertical	wooden case(W)			Carton(C)
	A1	D	H									N.W.	G.W.			
HV-4	58	110	72	80	138	118	11	⊕	g	35 KGS	18 KGS	MT-2	7KGS	7.5KGS (C)	0.3	1001-000
HV-6	78	150	80	102	205	163	11	⊕	17	40 KGS	20 KGS	MT-2	12.1KGS	12.7KGS (C)	0.4	1001-001
HV-8	100	205	102	135	265	219	14	⊕	17	80 KGS	40 KGS	MT-3	24.7KGS	26.2KGS (C)	0.8	1001-002
HV-10	106	254	109	163	321	276	14	⊗	17	90 KGS	50 KGS	MT-3	35.5KGS	37.3KGS (C)	2	1001-003
HV-12	123	305	125	194	388	330	16	⊗	18	120 KGS	60 KGS	MT-4	58.7KGS	69.8KGS (W)	2.6	1001-004
HV-14	123	353	125	225	445	389	16	⊗	18	130 KGS	70 KGS	MT-4	76.61KGS	90.3KGS (W)	3.2	1001-005
HV-16	128	406	130	255	500	435	16	⊗	18	140 KGS	70 KGS	MT-4	106.4KGS	123.1KGS (W)	4.2	1001-006

Optional Accessories

(Details on page A3)



Flange



Tailstock



Dividing Plate



3-Jaw Chuck For Rotary Table, Indexer

● Detail specification & Order NO. shown on page E9
The Fixing Hole is From Front



ORDER NO.

- VSC-5A SUIT FOR BS-0 OR HV-6, VUT-6, VU-150
- VSC-6A SUIT FOR BS-1 OR HV-8, 10, VUT-6, VU-200
- VSC-7A, 8A SUIT FOR BS-2 OR HV-10, 12, 14, VUT-10, 12
- VSC-10A SUIT FOR HV-14, 16

Reversible type

● For indexer, The fixing hole is from front.



ORDER NO.

- VSK-6A SUIT FOR CS-6, CC-6
- VSK-8A SUIT FOR CS-8, CC-8
- VSK-12A SUIT FOR CC-12

EXAMPLE :



W/O Flange



W/ Flange



W/ Dividing Plate

- Our Tables are made of high density Meehanite inspect angle to assure the excellent quality and durability.
- Use excellent machining center to process. Spindle end be applied accuracy bearing. Can be assured to keep very steady under load cutting.
- Worm is hardened and ground. The ratio is 90:1. The work table is graduated a full 360° so that one turn of the handle moves the table through 4°. Micro collar is graduated in steps of 1' min. And vernier scale makes settings down to 10 seconds possible.
- These Rotary Tables are popular for their excellent performance, practical design and reasonable cost. They are widely used for circular cutting work, angle setting, boring, spot-facing and similar work.
- Indexing accuracy of direct Indexing mechanism Maximum cumulative spacing error 1 minute.
- Please choose Front-Lock 3 Jaw chuck only.

ITEM NO.	TESTING OBJECTIVE	VARIATION(PER100mm) MAXIMUM TESTED
1	FLATNESS OF CLAMPING SURFACE(CONCAVE)	±0.015
2	PARALLELISM OF CLAMPING SURFACE TO BASE	±0.02
3	SQUARENESS OF CLAMPING SURFACE TO ANGLE FACE	±0.02
4	TRUE RUNNING OF CLAMPING SURFACE	±0.015
5	TRUE RUNNING OF CENTER HOLE MEASURED AT HOLE EDGE	±0.02

Optional For Rotary Table



A. DIVIDING PLATES DP-2, 3, 4, 5

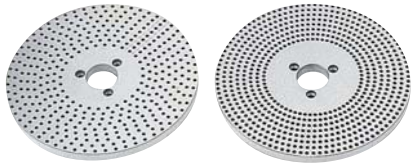

*DP-2 set include index plate, crank handle, 3 pcs screw, sector, & U Washer.

1 carton with 1 set. Gross weight: 3.5kgs.
Meas.: 0.13 CFT.

Number of the holes of Dividing Plates

EXAMPLE :

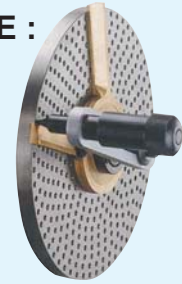

ORDER NO.	SUIT FOR MODEL	WEIGHT kgs	CODE NO.
*DP-2	for HV-8, VU-200	4.5	1001-031
DP-3	for HV-10, 12, 14, 16, VUT-10, VUT-12	4.6	1001-032
DP-4	for CS-6, 8	4.6	1001-033
DP-5	for VU-300	4.6	1001-034

Holes Number

A-Plate	26, 30, 34, 38, 41, 44, 47, 51, 57, 28, 32, 37, 39, 43, 46, 49, 53, 59
B-Plate	61, 67, 71, 77, 81, 87, 91, 97, 63, 69, 73, 79, 83, 89, 93, 99

A. DIVIDING PLATES DP-1



Holes Number

A-Plate	15, 16, 17, 18, 19, 20
B-Plate	21, 23, 27, 29, 31, 33
C-Plate	37, 39, 41, 43, 47, 49

ORDER NO.	SUIT FOR MODEL	WEIGHT kgs	CODE NO.
*DP-1	for HV-4, HV-6, VUT-6, VU-100, 150	1.4	1001-030

EXAMPLE :

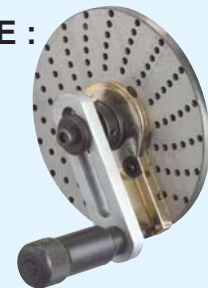

B. TAILSTOCK



TS-1

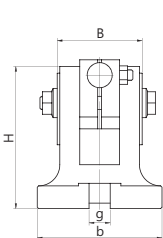

TS-1

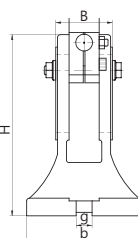
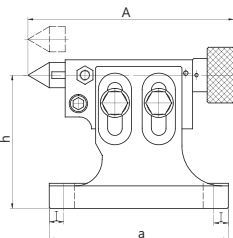

TS-2~TS-4

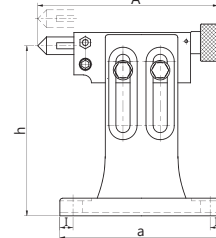

TS-3

Tailstock

Unit:mm

ORDER NO.	adjustable(h)		A	B	H	I	a	b	g	SUIT FOR MODEL	G.W. kgs	Meas. CFT	CODE NO.
	highest	lowest											
TS-1	108	80	155-180	64	107	11	134	94	16	HV-4, HV-6, VSI-4, VSI-5, BS-0, VUT-6, VU-100, VU-150	3.9	0.4	1001-022
TS-2	150	115	170-195	64	150	11	155	110	16	BS-1, CC-6, CS-6, HV-8	5.5	0.4	1001-023
TS-3	205	130	210-235	64	205	13	185	138	16	CS-8, HV-10, HV-12, CC-8, VUT-10, VUT-12, VU-200	8.1	0.4	1001-024
TS-4	260	182	210-235	75	260	17	205	144	16	HV-14, CC-12, HV-16	11.9	0.7	1001-025



Optional For Rotary Table



-0.035
-0.015
d FOR 3 JAW CHUCK

C. FLANGE

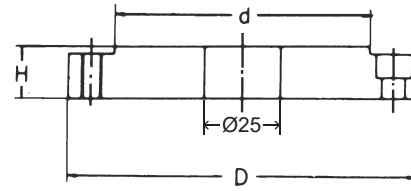

Flange

Unit:mm

- FLange for VSC-A TYPE
- FLT-103 For VSC-3F
 - FLT-104 For VSC-4F
 - FLT-0 For VSC-5F
 - FLT-1 For VSC-6F
 - FLT-2 For VSC-7F
 - FLT-3 For VSC-8F
 - FLT-103A For VSC-3A
 - FLT-104A For VSC-4A
 - FLT-0A For VSC-5A
 - FLT-1A For VSC-6A
 - FLT-2A For VSC-7A
 - FLT-3A For VSC-8A

ORDER NO.	D	d	H	SUIT FOR MODEL	WEIGHT kgs	CODE NO.
FLT-103	90	60	20	HV-4 VU-100	0.71	1001-036
FLT-104	113	80	20	HV-6 VU-150, VUT-6	1.0	1001-037
FLT-0	138	100	20	HV-6, 8 VU-150,200, VUT-6	1.9	1001-040
FLT-1	170	130	21	HV-8, 10 VU-200, VUT-10	3.3	1001-041
FLT-2	195	155	24	HV-10, 12, 14 VUT-10,12	5.2	1001-042
FLT-3	210	160	24	HV-10,12, 14, 16 VUT-12	4.9	1001-043

Unit:mm

ORDER NO.	D	d	H	SUIT FOR MODEL	T-NUT SIZE	BOLT	WEIGHT kgs	CODE NO.
FLT-103A	90	55	20	HV-4 VU-100	M8x10 3412M	M8x20L	0.71	1001-044
FLT-104A	113	72	20	HV-6 VU-150, VUT-6	M8x10 3412M	M8x20L	1.0	1001-045
FLT-0A	138	100	20	HV-6, 8 VU-150,200, VUT-6	M8x10 3412M	M8x20L	1.9	1001-046
FLT-1A	170	130	21	HV-8, 10 VU-200, VUT-10	M10x14 SPECIAL SIZE	M10x25L	3.3	1001-047
FLT-2A	195	155	24	HV-10, 12, 14 VUT-10,12	M10x14 SPECIAL SIZE	M10x25L	5.2	1001-048
FLT-3A	210	165	24	HV-10,12, 14, 16 VUT-12	M10x16 SPECIAL SIZE	M10x30L	4.9	1001-049

D. 3 JAW CHUCK

3-Jaw Chuck For Rotary Table, Indexer Economical Type

● Detail specification & Order NO. shown on page E9



ORDER NO.

- VSC-3A SUIT FOR HV-4, VU-100(FLT-103A)
- VSC-5A SUIT FOR BS-0 OR HV-6, VUT-6, VU-150(FLT-0A)
- VSC-6A SUIT FOR BS-1 OR HV-8, 10, VUT-6, VU-200(FLT-1A)
- VSC-7A, 8A SUIT FOR BS-2 OR HV-10, 12, 14, VUT-10, 12(FLT-2A,FLT-3A)
- VSC-10A SUIT FOR HV-14, 16

Reversible type

For indexer, The fixing hole is from front.

ORDER NO.

- VSK-6A SUIT FOR CS-6, CC-6
- VSK-8A SUIT FOR CS-8, CC-8
- VSK-12A SUIT FOR CC-12

ORDER NO.	D-Size	d1	d2	THREAD	SUIT FOR MODEL
VSC-5A	130mm(5")	115	100	3-M8	BS-0, HV-6, VUT-6, VU-150
VSC-6A	160mm(6")	142	130	3-M8	HV-8, HV-10, VUT-6, VU-200
VSC-7A	190mm(7 1/2")	172	155	3-M10	BS-2, HV-10,12,14, VUT-10,12
VSC-8A	200mm(8")	180	165	3-M10	
VSC-10A	250mm(10")	225	206	3-M12	HV-14,16

ORDER NO.	D-Size	d1	d2	THREAD	SUIT FOR MODEL
VSK-6A	160mm(6")	142	130	3-M8	CS-6, CC-6
VSK-8A	200mm(8")	180	165	3-M12	CS-8, CC-8
VSK-12A	315mm(10")	285	260	3-M16	CC-12